

Digital Video Camera Recorder **Mini DV** Digital Video Cassette

Operating Instructions

Before operating the unit, please read this manual thoroughly, and retain it for future reference.

Owner's Record

The model and serial numbers are located on the bottom. Record the serial number in the space provided below. Refer to these numbers whenever you call upon your Sony dealer regarding this product.

Model No. DCR-VX2000

Model No. AC-_____

Serial No. _____

Serial No. _____

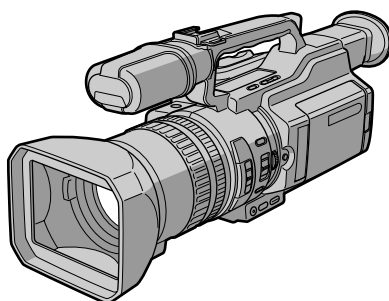

Digital Handycam



DCR-VX2000

Welcome!

Congratulations on your purchase of this Sony Digital Handycam camcorder. With your Digital Handycam, you can capture life's precious moments with superior picture and sound quality. Your Digital Handycam is loaded with advanced features, but at the same time it is very easy to use. You will soon be producing home video that you can enjoy for years to come.

WARNING

To prevent fire or shock hazard, do not expose the unit to rain or moisture.

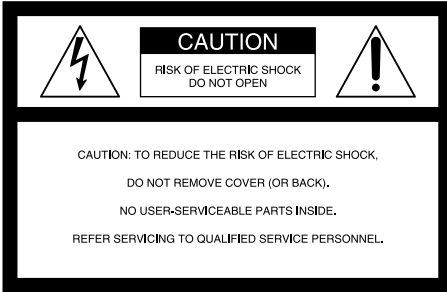

This symbol is intended to alert the user to the presence of uninsulated "dangerous voltage" within the product's enclosure that may be of sufficient magnitude to constitute a risk of electric shock to persons.



This symbol is intended to alert the user to the presence of important operating and maintenance (servicing) instructions in the literature accompanying the appliance.

Never expose the battery pack to temperatures above 140 °F (60 °C) such as in a car parked in the sun or under direct sunlight.

For customers in the U.S.A. and CANADA

DISPOSAL OF LITHIUM ION BATTERY.
LITHIUM ION BATTERY.
DISPOSE OF PROPERLY.

You can return your unwanted lithium ion batteries to your nearest Sony Service Center or Factory Service Center.

Note: In some areas the disposal of lithium ion batteries in household or business trash may be prohibited.

For the Sony Service Center nearest you call 1-800-222-SONY (United States only).

For the Sony Factory Service Center nearest you call 416-499-SONY (Canada only).

Caution: Do not handle damaged or leaking lithium ion battery.

For the customers in the U.S.A.

If you have any questions about this product, you may call: Sony Customer Information Center 1-800-222-SONY (7669) or write to: Sony Customer Information Center 1 Sony Drive, Mail Drop #T1-11, Park Ridge, NJ 07656

Declaration of Conformity

Trade Name:	SONY
Model No.:	DCR-VX2000
Responsible Party:	Sony Electronics Inc.
Address:	1 Sony Drive, Park Ridge, NJ, 07656 USA
Telephone No.:	201-930-6972

This device complies with Part 15 of the FCC Rules. Operation is subject to the following two conditions: (1) This device may not cause harmful interference, and (2) this device must accept any interference received, including interference that may cause undesired operation.

CAUTION

You are cautioned that any changes or modifications not expressly approved in this manual could void your authority to operate this equipment.

Note:

This equipment has been tested and found to comply with the limits for a Class B digital device, pursuant to Part 15 of the FCC Rules. These limits are designed to provide reasonable protection against harmful interference in a residential installation. This equipment generates, uses, and can radiate radio frequency energy and, if not installed and used in accordance with the instructions, may cause harmful interference to radio communications. However, there is no guarantee that interference will not occur in a particular installation. If this equipment does cause harmful interference to radio or television reception, which can be determined by turning the equipment off and on, the user is encouraged to try to correct the interference by one or more of the following measures:

- Reorient or relocate the receiving antenna.
- Increase the separation between the equipment and receiver.
- Connect the equipment into an outlet on a circuit different from that to which the receiver is connected.
- Consult the dealer or an experienced radio/TV technician for help.

For customers in CANADA

CAUTION

TO PREVENT ELECTRIC SHOCK, MATCH WIDE BLADE OF PLUG TO WIDE SLOT, FULLY INSERT.

"Memory Stick"

For the customers in the U.S.A.

This device complies with Part 15 of the FCC Rules. Operation is subject to the following two conditions: (1) This device may not cause harmful interference, and (2) this device must accept any interference received, including interference that may cause undesired operation.

For customers in CANADA

This Class B digital apparatus complies with Canadian ICES-003.

Table of contents

Quick Start Guide	4	Editing	
Getting started		Dubbing a tape	73
Using this manual	6	Dubbing only desired scenes	
Checking supplied accessories	8	– Digital program editing	75
Step 1 Preparing the power supply	9	Using with an analog video unit and a PC	
Step 2 Inserting a cassette	14	– Signal convert function	86
Recording – Basics		Recording video or TV programs	87
Recording a picture	15	Inserting a scene from a VCR	
Shooting backlit subjects (BACK LIGHT)	22	– Insert editing	91
Using the spot light function	23	Audio dubbing	93
Self-timer recording	24	Superimposing a title	97
Checking the recording – END SEARCH / EDITSEARCH / Rec Review	25	Making your own titles	101
Playback – Basics		Labeling a cassette	103
Playing back a tape	26	Erasing the cassette memory data	105
Viewing the recording on TV	30	Customizing Your Camcorder	
Advanced Recording Operations		Changing the menu settings	107
Recording a still image on a tape		Resetting the date and time	114
– Tape Photo recording	31	“Memory Stick” Operations	
Shooting with all the pixels		Using a “Memory Stick” – introduction	115
– PROG. SCAN	34	Recording still images on a “Memory Stick”	
Using the guide frame	35	– Memory Photo recording	120
Using the wide mode	36	Superimposing a still image in a “Memory Stick” on a moving picture	
Using the fader function	37	– MEMORY MIX	124
Using special effects – Picture effect	39	Recording an image from a mini DV tape as a still image	127
Using special effects – Digital effect	40	Copying still images from a mini DV tape	
Shooting with manual adjustment	43	– Photo save	130
Adjusting the white balance	49	Viewing a still picture – Memory Photo playback	132
Adjusting recording level manually – Sound recording level	51	Copying an image recorded on a “Memory Stick” to mini DV tapes	135
Presetting the adjustment for picture quality		Playing back images continuously	
– Custom preset	53	– SLIDE SHOW	137
Using the PROGRAM AE function	55	Preventing accidental erasure	
Focusing manually	58	– Image protection	138
Interval recording	59	Deleting images	139
Frame by frame recording – Cut recording ..	61	Writing a print mark – Print mark	142
Marking an Index	62	Additional Information	
Advanced Playback Operations		Usable cassettes	143
Quickly locating a scene using the zero set memory function	63	About i.LINK	145
Searching for a recording by index		Troubleshooting	146
– Index search	64	Self-diagnosis display	152
Searching the boundaries of recorded tape by title – Title search	66	Warning indicators and messages	153
Searching a recording by date		Using your camcorder abroad	155
– Date search	67	Maintenance information and precautions	156
Searching for a photo		Specifications	161
– Photo search/Photo scan	69	Quick Reference	
Playing back a tape with picture effects	71	Identifying the parts and controls	162
Playing back a tape with digital effects	72	Quick Function Guide	170
		Index	171

Quick Start Guide



This guide introduces you to the basic way of recording/
playback. See the pages in parentheses “()” for more
information.

1 Connecting the power cord (p. 13)

Use the battery pack when using your camcorder outdoors (p. 9).

Connect the plug with its
▲ mark facing toward the
LCD panel side.

AC power adaptor
(supplied)

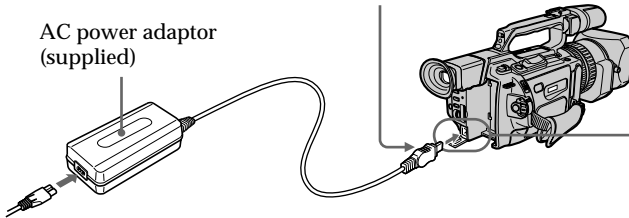

Open the DC IN jack
cover.

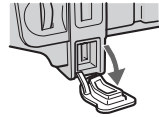

2 Inserting a cassette (p. 14)

- 1** While pressing the small blue button on the EJECT switch, slide it in the direction of the arrow.



- 2** Push the middle portion of the back of the cassette to insert it. Insert the cassette into the cassette compartment with the window facing out and the write-protect tab facing upward.

Window

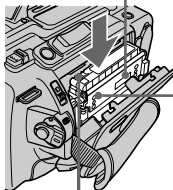

Write-protect tab

- 3** Close the cassette compartment by pressing the PUSH mark on it.

- 4** Close the cassette lid by pressing the PUSH button on the cassette lid.

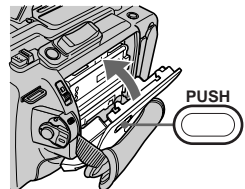

3 Recording a picture (p. 15)

Viewfinder
When the LCD panel is closed, use the viewfinder placing your eye against its eyecup.

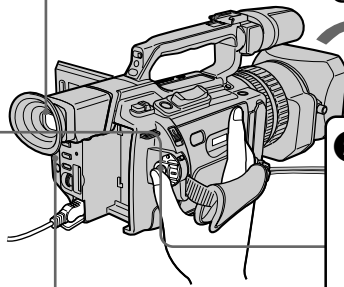

1 Remove the hood cap.

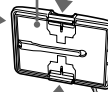

4 Press START/STOP. Your camcorder starts recording. To stop recording, press START/STOP again.



3 Slide OPEN back in the ► mark direction to open the LCD panel.



2 Set the POWER switch to CAMERA while pressing the small green button. The date and time is indicated for five seconds.

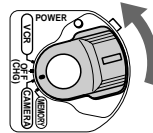

If the ND1 or ND2 indicator flashes, see page 46.

4 Monitoring the playback picture on the LCD screen (p. 26)

1 Set the POWER switch to VCR while pressing the small green button.

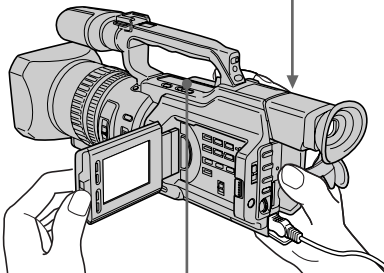
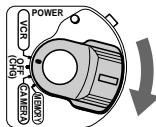

2 Press ◀◀ to rewind the tape.



3 Press ▶▶ to start playback.



NOTE

Do not pick up your camcorder by holding the viewfinder, the LCD panel, the battery pack, or the microphone.

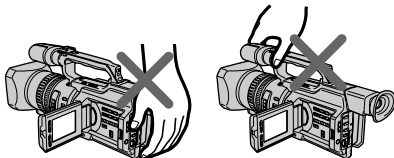
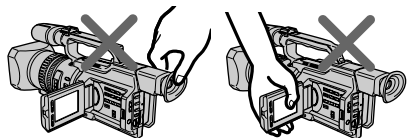

Using this manual

As you read through this manual, buttons and settings on your camcorder are shown in capital letters.

e.g. Set the POWER switch to CAMERA.

When you carry out an operation, you can hear a beep or a melody sound to indicate that the operation is being carried out.

Note on cassette memory

Your camcorder is based on the DV format. You can only use mini DV cassettes with your camcorder. We recommend that you use a tape with cassette memory **CM**.

The functions which require different operations depending on whether or not the tape has cassette memory are:

- Searching the end point of the recording – end search (p. 25, 29)
- Searching a recording by index – index search (p. 64)
- Searching a recording by date – date search (p. 67)
- Searching for a photo – photo search (p. 69).

The functions you can operate only with cassette memory are:

- Searching the boundaries of recorded tape by title – title search (p. 66)
- Superimposing a title (p. 97)
- Making your own titles (p. 101)
- Labeling a cassette (p. 103).

For details, see page 143.



You see this mark in the introduction of the features that are operated only with cassette memory.

Tapes with cassette memory are marked with **CM** (Cassette Memory).

Note on TV color systems

TV color systems differ from country to country. To view your recordings on a TV, you need an NTSC system-based TV.

Copyright precautions

Television programs, films, video tapes, and other materials may be copyrighted. Unauthorized recording of such materials may be contrary to the provision of the copyright laws.

Precautions on camcorder care

- The LCD screen and the viewfinder are manufactured using high-precision technology. However, there may be some tiny black points and/or bright points (red, blue, green or white) that constantly appear on the LCD screen and in the viewfinder. These points occur normally in the manufacturing process and do not affect the recorded picture in any way. Effective ratio of pixels and/or screen is 99.99% or more.
- Do not let your camcorder get wet. Keep your camcorder away from rain and sea water. Letting your camcorder get wet may cause your camcorder to malfunction. Sometimes this malfunction cannot be repaired [a].
- Never leave your camcorder exposed to temperatures above 60 °C (140 °F), such as in a car parked in the sun or under direct sunlight [b].
- Do not place your camcorder so as to point the viewfinder or the LCD screen or lens toward the sun. The inside of the viewfinder, LCD screen, or lens may be damaged [c].

[a]

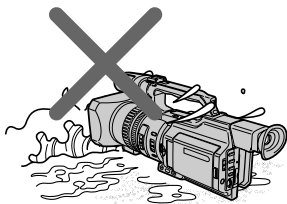

[b]

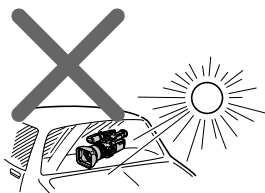

[c]

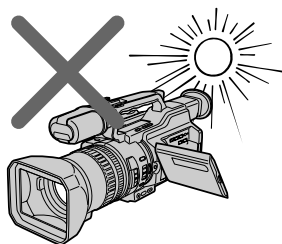

Contents of the recording cannot be compensated if recording or playback is not made due to a malfunction of the camcorder, video tape, etc.

Checking supplied accessories

Make sure that the following accessories are supplied with your camcorder.

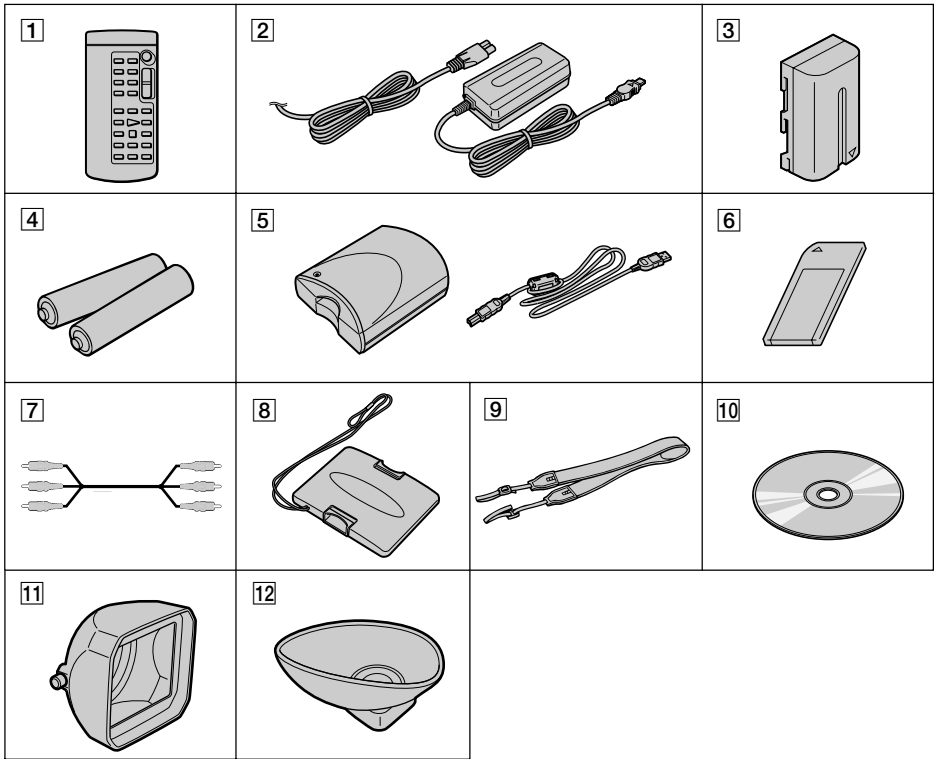

1 Wireless Remote Commander (1) (p. 167)

2 AC-L10A/L10B/L10C AC power adaptor (1), Power cord (1) (p. 10)

3 NP-F330 battery pack (1) (p. 9, 10)

4 Size AA (R6) battery for Remote Commander (2) (p. 168)

5 Memory Stick Reader/Writer (1), USB cable (1)

6 "Memory Stick" (1) (p. 115)

7 A/V connecting cable (1) (p. 30, 73)

8 Hood cap (1) (p. 15)

9 Shoulder strap (1) (p. 165)

10 Application software: PictureGear 4.1Lite (CD ROM) (1) (p. 134)

11 Lens hood (1) (p. 164)

12 Eyecup (large) (1) (p. 19)

Step 1 Preparing the power supply

Installing the battery pack

Install the battery pack to use your camcorder outdoors.

- (1) Lift up the viewfinder.
- (2) Insert the battery pack in the direction of the ▼ mark on the battery pack. Slide the battery pack until it is locked.

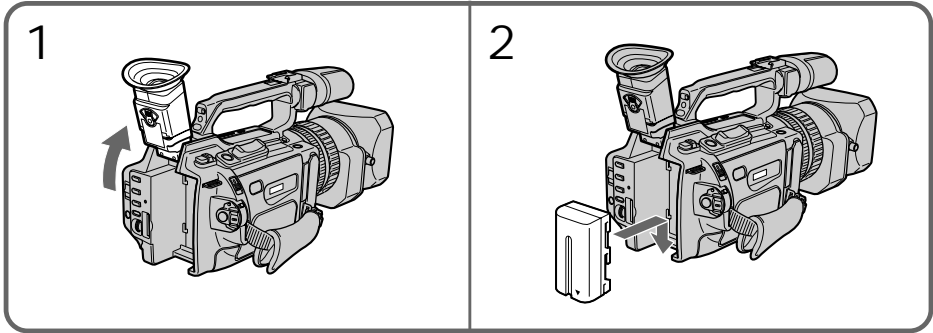

To remove the battery pack

Lift up the viewfinder.

Slide the battery pack out in the direction of the arrow while pressing BATT RELEASE down.

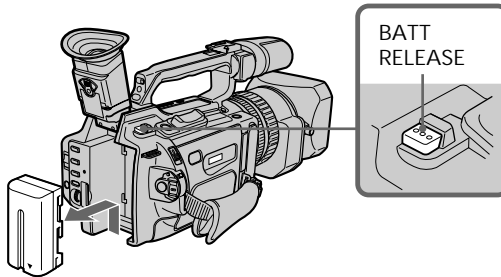

Step 1 Preparing the power supply

Charging the battery pack

Use the battery pack after charging it.

Your camcorder operates only with the “InfoLITHIUM” battery pack (L series).

- (1) Open the DC IN jack cover and connect the AC power adaptor supplied with your camcorder to the DC IN jack with the plug’s ▲ mark facing toward the LCD panel side.
- (2) Connect the power cord to the AC power adaptor.
- (3) Connect the power cord to a wall outlet.
- (4) Set the POWER switch to OFF (CHG). Charging begins.

The remaining battery time is indicated in minutes on the display window.

When the remaining battery indicator changes to , normal charge is completed. To fully charge the battery (full charge), leave the battery pack attached for about one hour after normal charge is completed until FULL appears on the display window. Fully charging the battery allows you to use the battery longer than usual.

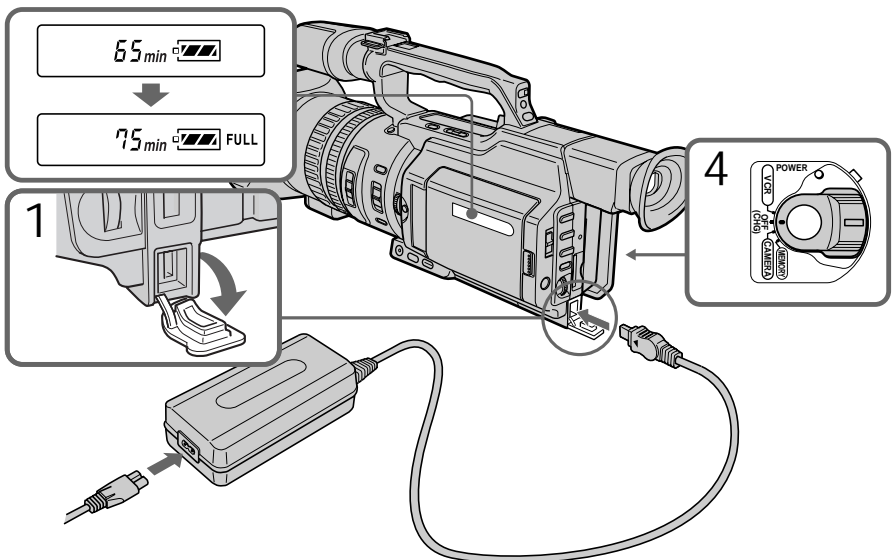

After charging the battery pack

Disconnect the AC power adaptor from the DC IN jack on your camcorder.

Note on the remaining battery time indicator

The remaining battery time indicator on the LCD screen/display window or in the viewfinder indicates the recording time using the viewfinder. The indicator may not be correct, depending on the conditions in which you are recording. When you close the LCD panel and open it again, it takes about one minute for the correct remaining battery time to be displayed.

Notes

- Prevent metallic objects from coming into contact with the metal parts of the DC plug of the AC power adaptor. This may cause a short-circuit, damaging the AC power adaptor.
- Keep the battery pack dry.
- When the battery pack is not to be used for a long time, charge the battery pack once fully, and then use it until it fully discharges again. Keep the battery pack in a cool place.

Step 1 Preparing the power supply

Until your camcorder calculates the actual remaining battery time
“- - - min” appears in the display window.

While charging the battery pack, no indicator appears or the indicator flashes in the display window in the following cases:

- The battery pack is not installed correctly.
- The AC power adaptor is disconnected.
- Something is wrong with the battery pack.

Charging time

Battery pack	Full charge (Normal charge)
NP-F330 (supplied)	150 (90)
NP-F530/F550	210 (150)
NP-F730/F730H/F750	300 (240)
NP-F930/F950	390 (330)
NP-F960	420 (360)

Approximate minutes to charge an empty battery pack

Recording time

Battery pack	Recording with the viewfinder		Recording with the LCD screen	
	Continuous*	Typical**	Continuous*	Typical**
NP-F330 (supplied)	75 (65)	40 (35)	60 (55)	30 (30)
NP-F530	120 (110)	65 (60)	100 (90)	55 (50)
NP-F550	150 (135)	80 (75)	130 (115)	70 (60)
NP-F730	265 (240)	145 (130)	230 (205)	125 (110)
NP-F730H/F750	315 (275)	175 (150)	265 (235)	145 (130)
NP-F930	410 (365)	225 (200)	355 (320)	195 (175)
NP-F950	475 (430)	265 (240)	405 (360)	225 (200)
NP-F960	575 (515)	320 (285)	480 (430)	265 (240)

Approximate minutes of recording time when you use a fully charged battery

Numbers in parentheses “()” indicate the time using a normally charged battery. You cannot use the NP-500/510/710 battery pack on your camcorder.

* Approximate continuous recording time at 25 °C (77 °F). The battery life will be shorter if you use your camcorder in a cold environment.

** Approximate minutes when recording while you repeat recording start/stop, zooming and turning the power on/off. The actual battery life may be shorter.

Step 1 Preparing the power supply

Playing time

Battery pack	Playing time on LCD screen	Playing time with LCD closed
NP-F330 (supplied)	90 (80)	110 (95)
NP-F530	150 (135)	190 (165)
NP-F550	185 (165)	225 (195)
NP-F730	305 (275)	385 (345)
NP-F730H/F750	375 (335)	460 (415)
NP-F930	475 (430)	605 (540)
NP-F950	570 (510)	705 (630)
NP-F960	680 (610)	830 (745)

Approximate minutes of playing time when you use a fully charged battery

Numbers in parentheses “ () ” indicate the time using a normally charged battery. The battery life will be shorter if you use your camcorder in a cold environment. You cannot use the NP-500/510/710 battery pack on your camcorder.

Notes

- The supplied battery pack is charged a little.
- Some types of the battery packs may not be sold in your region or country.

What is “InfoLITHIUM?”

The “InfoLITHIUM” is a lithium ion battery pack which can exchange data such as battery consumption with compatible video equipment. This unit is compatible with the “InfoLITHIUM” battery pack (L series). Your camcorder operates only with the “InfoLITHIUM” battery. “InfoLITHIUM” battery packs (L series) have the  mark.

“InfoLITHIUM” is a trademark of Sony Corporation.

If the camcorder is immediately turned off

Even if the remaining battery time is enough to operate, charge the battery pack fully again. The correct remaining time is displayed.

Step 1 Preparing the power supply

Connecting to a wall outlet

When you use your camcorder for a long time, we recommend that you power it from a wall outlet using the AC power adaptor.

- (1) Open the DC IN jack cover and connect the AC power adaptor to the DC IN jack on your camcorder with the plug's ▲ mark facing toward the LCD panel side.
- (2) Connect the power cord to the AC power adaptor.
- (3) Connect the power cord to a wall outlet.

Getting started

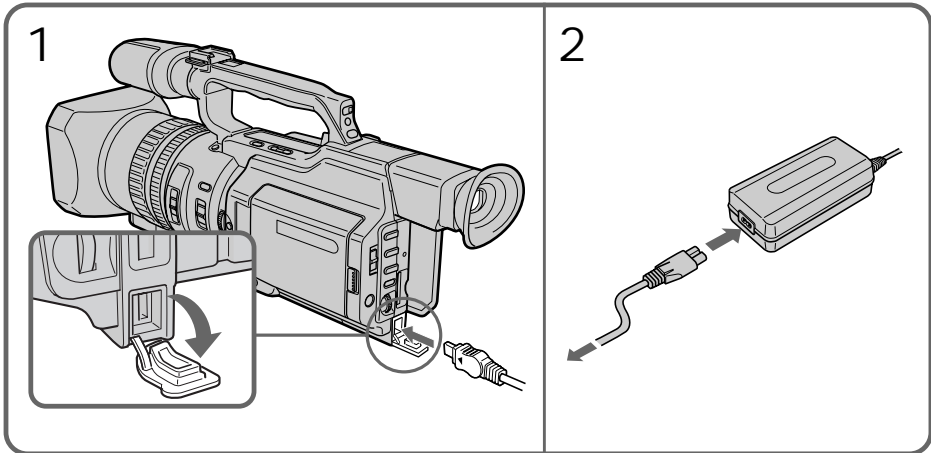

Precaution

The set is not disconnected from the AC power source (house current) as long as it is connected to the wall outlet, even if the set itself has been turned off.

Notes

- The power cord must only be changed at an authorized service shop.
- AC power adaptor can supply power even if the battery pack is attached to your camcorder.
- The DC IN jack has source priority. This means that the battery pack cannot supply any power if the power cord is connected to the DC IN jack, even when the power cord is not plugged into a wall outlet.

Using a car battery

Use the Sony DC Adaptor/Charger (not supplied).

Step 2 Inserting a cassette

- (1) Install the power source.
- (2) While pressing the small blue button on the EJECT switch, slide it in the direction of the arrow. After the cassette lid is opened, the cassette compartment automatically opens.
- (3) Push the middle portion of the back of the cassette to insert it.
Insert the cassette in a straight line deeply into the cassette compartment with the window facing out and the write-protect tab facing upward.
- (4) Close the cassette compartment by pressing the PUSH mark on it.
- (5) Close the cassette lid until it clicks by pressing the PUSH button on the lid.

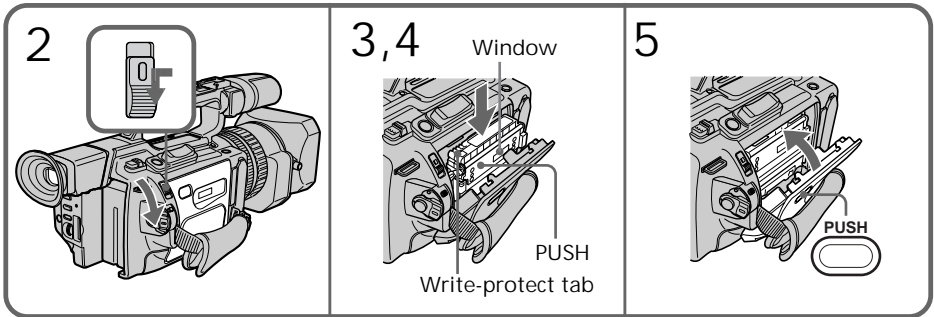

To eject a cassette

Follow the procedure above, and take out the cassette in step 3.

Notes

- The cassette lid will not be closed when you press any part of the lid other than the PUSH button.
- Do not catch your finger in the cassette lid.

When you use mini DV cassettes with cassette memory

Read the instruction about cassette memory to use this function properly (p. 143).

To prevent accidental erasure

Slide the write-protect tab on the cassette to the protect position.

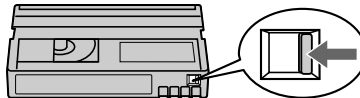

If the grip strap prevents the cassette lid from opening fully
Adjust the length of the grip strap (p. 165).

If  flashes even if the cassette has been inserted
Press the PUSH button again to close the cover firmly.

Recording a picture

Your camcorder automatically focuses for you.

- (1) Remove the hood cap and pull the hood cap string to fix it.
- (2) Install the power source and insert a cassette. See “Step 1” and “Step 2” for more information (p. 9 to 14).
- (3) Set the POWER switch to CAMERA while pressing the small green button. Your camcorder is set to the standby mode.
- (4) Slide OPEN in the direction of the ► mark to open the LCD panel. The picture now being shot is displayed on the LCD screen, and it disappears from the viewfinder screen.
- (5) Press START/STOP. Your camcorder starts recording. The “REC” indicator appears. The camera recording lamps located on the front and rear of your camcorder light up. To stop recording, press START/STOP again. You can use REC START/STOP located on the front instead of START/STOP on the rear.

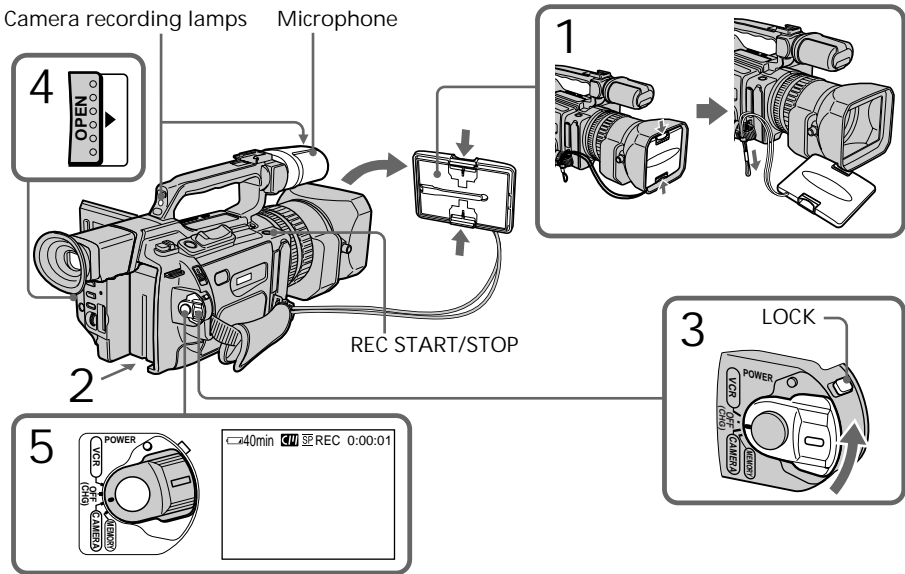

If the ND1 or ND2 indicator flashes on the LCD screen or in the viewfinder
The ND filter is necessary. Set the ND FILTER selector to 1 or 2. However, if you change the position during recording, the brightness of the picture may change or audio noise may occur. This is not a malfunction. We recommend that you check the position of the ND FILTER selector before shooting. See “Using the ND filter” on page 46.

Notes

- Fasten the grip strap firmly.
- Do not touch the microphone during recording.

Recording a picture

Note on the recording mode

Your camcorder records and plays back in SP (standard play) mode and in LP (long play) mode. Select SP or LP in the menu settings. In LP mode, you can record 1.5 times as long as in SP mode.

When you record a tape on your camcorder in LP mode, we recommend playing the tape on your camcorder.

Note on the LOCK switch

When you slide the LOCK switch to the left, the POWER switch can no longer be set to MEMORY accidentally. The LOCK switch is set to the right as a default setting. We recommend that you set the LOCK switch to the left when you record on a mini DV cassette.

Note on the progressive mode

If you intend to use the images on your PC or play the images back as still images, we recommend that you set PROG. SCAN to ON in the menu settings before shooting (p. 34). The picture quality may improve in this mode, but if you shoot a moving subject, the image may shake when it is played back.

To enable smooth transition

Transition between the last scene you recorded and the next scene is smooth as long as you do not eject the cassette even if you turn off your camcorder. When you use a tape with cassette memory, however, you can make the transition smooth even after ejecting the cassette if you use the end search function (p. 25).

However, check the following:

- When you change the battery pack, set the POWER switch to OFF (CHG).
- Do not mix recordings in the SP mode and ones in the LP mode on one tape.

Note on tape transition

The playback picture may be distorted or the time code may not be written properly between scenes when:

- You change the recording mode (SP/LP).
- You record in LP mode.

If you leave your camcorder in standby mode for five minutes while the cassette is inserted

Your camcorder automatically turns off. This is to prevent tape wear and save battery power. To resume the standby mode, set the POWER switch to OFF (CHG), and to CAMERA again. When a cassette is not inserted, your camcorder does not turn off.

Adjusting the LCD screen

The LCD panel is opened up to 90 degrees and it rotates about 90 degrees to the viewfinder side and about 180 degrees to the lens side.

If you turn the LCD panel over so that it faces the other way in standby or recording mode, the  indicator appears on the LCD screen and in the viewfinder (Mirror mode).

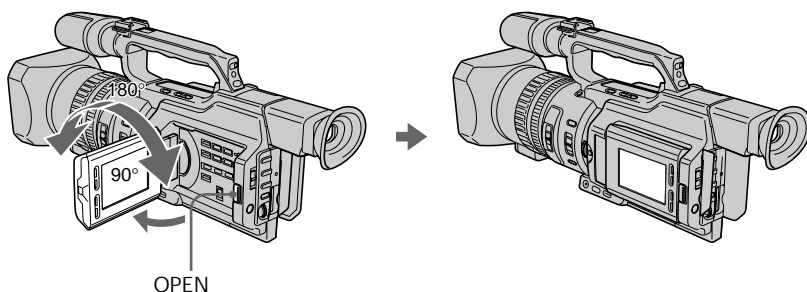

To close the LCD panel, set it vertically and swing it into the camcorder body until it clicks.

Note

When opening the LCD panel, the viewfinder is automatically turned off, however, it is not turned off when the LCD panel is turned over or the camcorder is in mirror mode.

When you use the LCD screen outdoors in direct sunlight

The LCD screen may be difficult to see. If this happens, we recommend that you use the viewfinder.

When you adjust the angle of the LCD panel

Make sure that the LCD panel is opened up to 90 degrees.

When using both the LCD screen and the viewfinder during shooting

The usable time of the battery pack when using both the LCD screen and the viewfinder will be shorter a little than when using the viewfinder only.



Pictures in the mirror mode

The picture on the LCD screen is a mirror-image. However, the recording picture will be normal.

During recording in mirror mode

ZERO SET MEMORY on the Remote Commander does not work.

Indicators in the mirror mode

The STBY indicator appears as  and REC as . Some of the other indicators appear mirror-reversed and others are not displayed. However, if you close the LCD panel with the LCD screen turned over, indicators appear normally.

Recording a picture

Adjusting the brightness of the LCD screen

To adjust the brightness of the LCD screen, press LCD BRIGHT + or -. The battery life is longer when the LCD panel is closed. Use the viewfinder instead of the LCD screen to save the battery power.

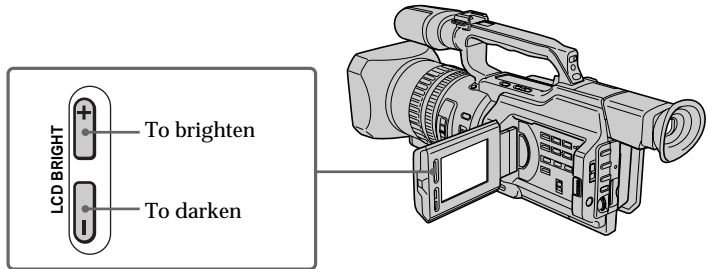

On the LCD screen backlight

You can change the brightness of the backlight. Select LCD B.L. in the menu settings (p. 107).

Even if you do the LCD screen adjustment using the LCD BRIGHT +/- buttons, or using LCD B.L. and LCD COLOR items in the menu settings The recorded picture will not be affected.

Recording in a low position

You can record in a low position to get an interesting recording angle. Lift up the viewfinder or rotate the LCD panel with the screen facing up to record from a low position. In this case, it is useful to use the REC START/STOP button located on the front or the camcorder.

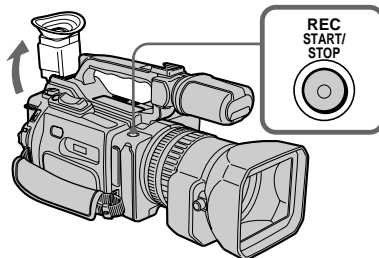

After recording

- (1) Set the POWER switch to OFF (CHG).
- (2) Close the LCD panel.
- (3) Eject the cassette.
- (4) Remove the battery pack.

Adjusting the viewfinder

If you record pictures with the LCD panel closed, check the picture with the viewfinder. Adjust the viewfinder lens to your eyesight so that the indicators in the viewfinder come into sharp focus.

Lift up the viewfinder and move the viewfinder adjustment lever.

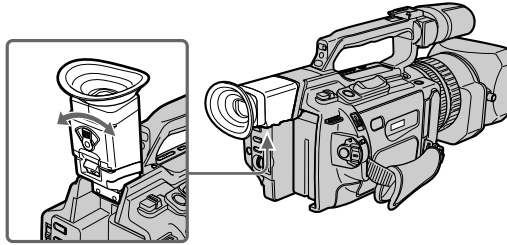

To adjust the brightness of the viewfinder screen, use the VF B.L. item in the menu settings (p. 107).

Even if you adjust the viewfinder screen backlight
The recorded picture will not be affected.

When the shooting conditions are too bright
Use the supplied large eyecup. Fit it onto the camcorder by stretching the corners a little. You can attach it with the large part of it located on both left and right.

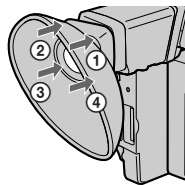

Recording a picture

Using the zoom feature

To zoom using the zoom lever

Press the power zoom lever a little for a slower zoom. Press it deeper for a faster zoom. Using the zoom function sparingly results in better-looking recordings.

“T” side: for telephoto (subject appears closer)

“W” side: for wide-angle (subject appears farther away)

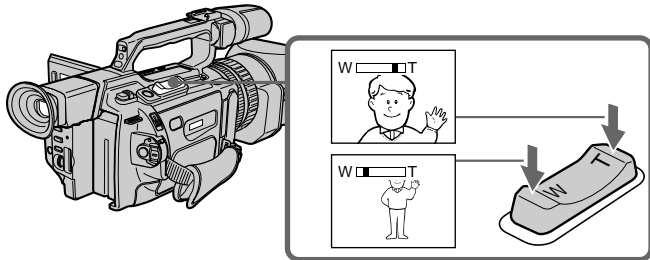

When you shoot close to a subject

If you cannot get a sharp focus, press the “W” side of the power zoom lever until the focus is sharp. You can shoot a subject that is at least about 80 cm (about 2 feet 5/8 inch) away from the lens surface in the telephoto position, or about 1 cm (about 1/2 inch) away in the wide-angle position.

To zoom using the zoom ring

Using the zoom ring, you can control the zoom by your desired speed and you can make fine adjustments.

During recording, turn the zoom ring to the desired speed.

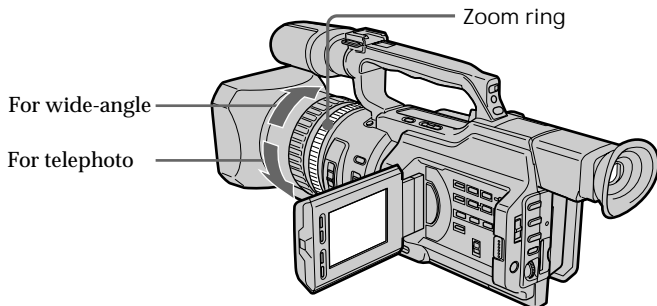

Note

If you turn the zoom ring quickly, the zoom may not respond to the zoom ring. Rotate the zoom ring with appropriate speed.

Using the digital zoom – Zoom greater than 12×

Zoom greater than 12× is performed digitally, if you set D ZOOM to 24× or 48× in the menu settings. The digital zoom function is set to OFF as a default setting (p. 107). If you use the digital zoom function, the picture quality deteriorates.

The right-ended portion of the bar shows the digital zooming zone. The digital zooming zone appears when you set D ZOOM to 24× or 48×.

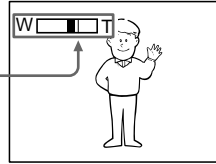

You cannot use the digital zoom:

- When you set PROG. SCAN to ON in the menu settings (p. 107).
- When the POWER switch is set to MEMORY.

Indicators displayed during recording

The indicators are not recorded on the tapes.

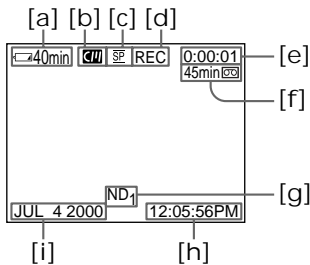

[a] Remaining battery time indicator

This appears after you turn on the power and wait for a while.

[b] Cassette memory indicator

This appears when using a tape with cassette memory.

[c] Recording mode indicator

[d] STBY/REC indicator

[e] Time code indicator/Tape counter

[f] Remaining tape indicator

This appears after you insert a cassette.

[g] ND filter indicator

This flashes when the ND FILTER selector should be set. After you have set the ND FILTER selector, the ND FILTER position selected is indicated. (When the ND OFF position is selected, the indication disappears.)

[h] Time indicator

The time is displayed about five seconds after the POWER switch is set to CAMERA or MEMORY.

[i] Date indicator

The date is displayed about five seconds after the POWER switch is set to CAMERA or MEMORY.

Recording a picture

Time code

The time code indicates the recording or playback time, "0:00:00" (hours : minutes : seconds) in CAMERA mode and "0:00:00:00" (hours : minutes : seconds : frames) in VCR mode. You cannot rewrite only the time code. Your camcorder uses the drop frame mode.

Remaining tape indicator

The indicator may not be displayed accurately depending on the tape.

Note on recording date/time

Recording date/time is not displayed during shooting, however, it is automatically recorded on the tape. You can check the recording date/time during playback by pressing DATA CODE.

Shooting backlit subjects (BACK LIGHT)

When you shoot a subject with the light source behind the subject or a subject with a light background, use the backlight function.

Press BACK LIGHT in standby, recording, or memory mode.

The  indicator appears on the LCD screen or in the viewfinder.

To cancel, press BACK LIGHT again.

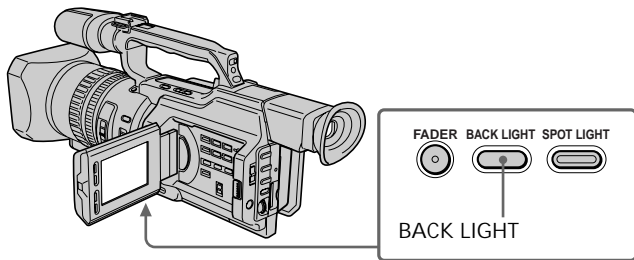

If you press one of the following buttons when using the backlight function

The backlight function will be canceled.

- SPOT LIGHT
- EXPOSURE

When you manually adjust the exposure

You cannot use the backlight function.

Using the spot light function

This function prevents people's faces, for example, from appearing excessively white when shooting subjects lit by strong light, such as in the theater.

Press SPOT LIGHT in standby, recording, or memory mode.

The  indicator appears on the LCD screen or in the viewfinder.

To cancel, press SPOT LIGHT again.

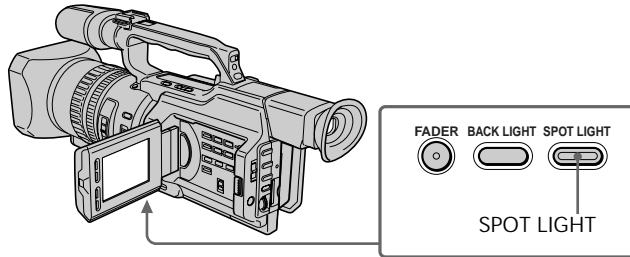

If you press one of the following buttons when using the spot light function
The spot light function will be canceled.

- BACK LIGHT
- EXPOSURE

When you manually adjust the exposure
You cannot use the spot light function.



You cannot use the spot light mode while in the following settings:

- Shutter speed value of 1/30 or smaller
- Old movie
- Low lux mode of the PROGRAM AE function

Recording a picture

Self-timer recording

You can make a recording with the self-timer. This recording is useful when you want to record yourself. You can also use the Remote Commander.

- (1) Press  (self-timer) in standby mode. The  (self-timer) indicator appears on the LCD screen or in the viewfinder.
- (2) Press START/STOP.
Self-timer starts counting down from 10 seconds with a beep sound. In the last two seconds of the countdown, the beep sound gets faster, then recording starts automatically.

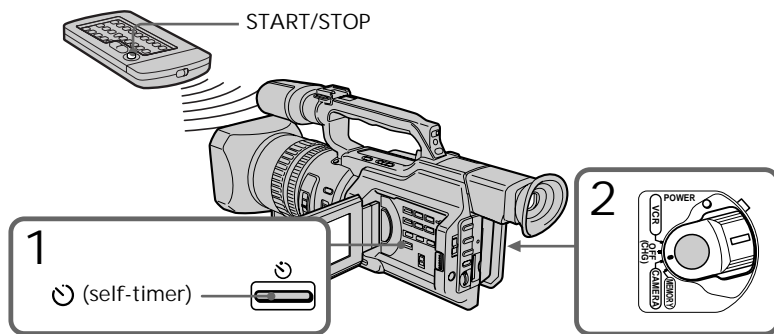

To stop the self-timer before recording

Press START/STOP again.

Use the Remote Commander for convenience.



To record still pictures on tapes using the self-timer

Press PHOTO in step 2 (p. 32).

To record still pictures on a "Memory Stick" using the self-timer

Press , then press PHOTO in memory mode (p. 123).

To cancel self-timer recording

Press  so that the  indicator disappears from the LCD or viewfinder screen while your camcorder is in standby mode.

Note

The self-timer recording is automatically canceled when:

- Self-timer recording is finished.
- The POWER switch is set to OFF (CHG) or VCR.

Checking the recording

– END SEARCH / EDITSEARCH / Rec Review

You can use these buttons to check recorded pictures or shoot so that the transition between the last recorded scene and the next scene you will record is smooth.

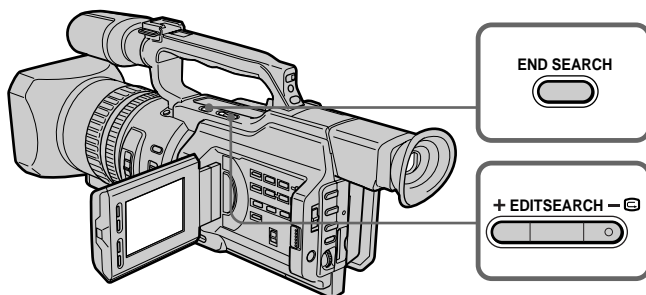

Searching the end point of the recording — END SEARCH

You can easily go to the end of the last recorded portion.

Press END SEARCH in standby mode.

The camcorder rewinds or fast-forwards the tape and the last five-second recorded picture is played back. After playback the camcorder turns to standby mode. You can monitor the sound from the speaker or headphones.

Changing the next recording start point — EDITSEARCH

You can change the next recording start point in standby mode.

Hold down the +/- side of EDITSEARCH in standby mode. The recorded picture is played back.

+: to go forward

-: to go backward

Release EDITSEARCH to stop playback. If you press START/STOP, re-recording begins from the point you released EDITSEARCH. You cannot monitor the sound.

Checking the last recorded picture — Rec Review

You can check the last recorded portion.

Press the - (⊖) side of EDITSEARCH momentarily in standby mode.

The last few-seconds of picture is played back and the camcorder returns to standby. You can monitor the sound from the speaker or headphones.

End search function

When you use a tape without cassette memory, the end search function does not work once you eject the cassette after you have recorded on the tape. If you use a tape with cassette memory, the end search function works even once you eject the cassette.

If there is a blank portion at the beginning or between the recorded portions, the end search function may not work correctly (p. 143).

Playing back a tape

You can monitor the playback picture on the LCD screen. If you close the LCD panel, you can monitor the playback picture in the viewfinder. You can also control playback using the Remote Commander supplied with your camcorder.

- (1) Install the power source and insert the recorded tape.
- (2) Set the POWER switch to VCR while pressing the small green button. The video control buttons light up.
- (3) Slide OPEN in the direction of the ► mark to open the LCD panel.
- (4) Press ◀◀ to rewind the tape.
- (5) Press ► to start playback.
- (6) To adjust the volume, press either of the VOLUME +/- buttons .

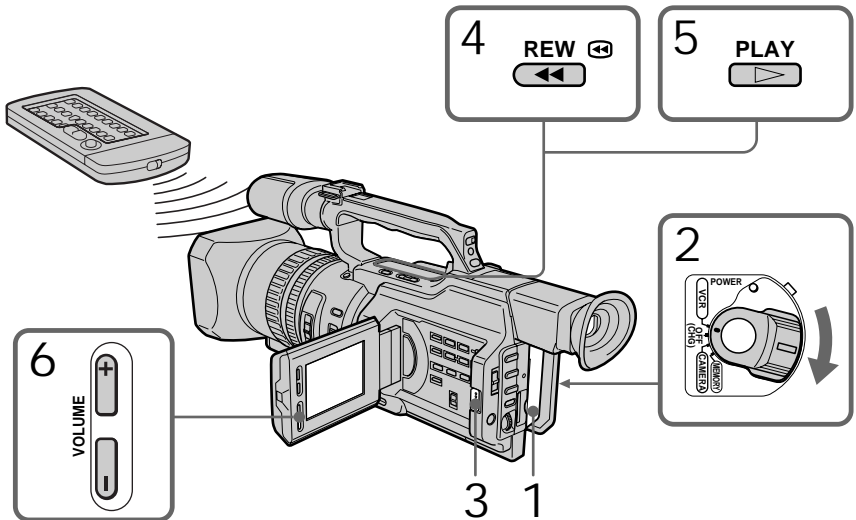

To stop playback
Press ■.

Playing back a tape

When monitoring on the LCD screen

You can turn the LCD panel over and move it back to the camcorder body with the LCD screen facing out.

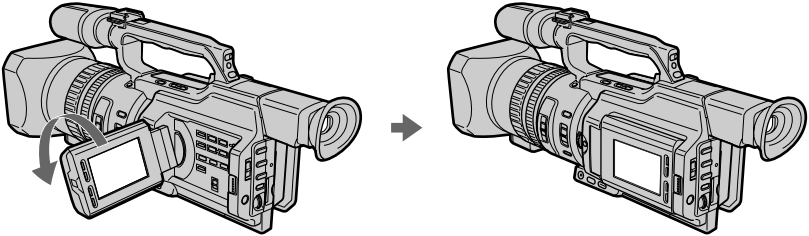

When you close the LCD panel

You cannot monitor the sound from the speaker. However, when the LCD panel is turned over to view on the LCD screen, you can monitor the sound from the speaker.

To control the display of the screen indicators

Press DISPLAY on the camcorder or on the Remote Commander supplied with your camcorder.

The indicators appear on the LCD screen.

To make the indicators disappear, press DISPLAY again.

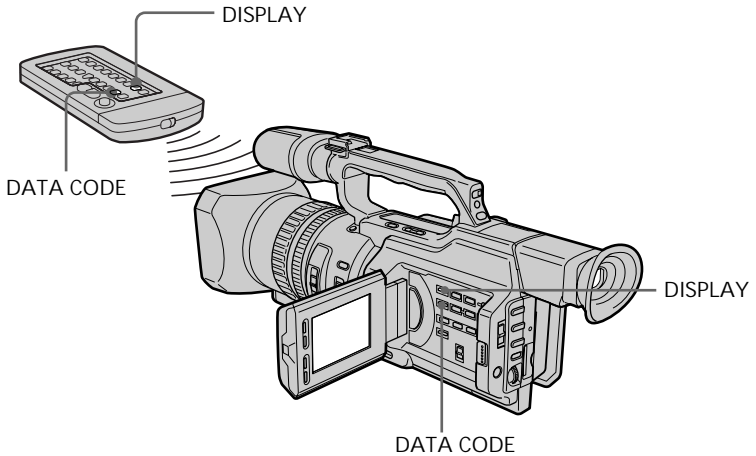

Playing back a tape

Using the data code function

Your camcorder automatically records not only images on the tape but also the recording data (date/time or various settings when recorded) (Data code).

Press DATA CODE on the camcorder or on the Remote Commander supplied with your camcorder in playback mode.

The display changes as follows:

date/time → various settings (SteadyShot, white balance, gain, shutter speed, aperture value, exposure mode) → no indicator

Date/time

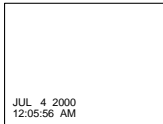

Various settings

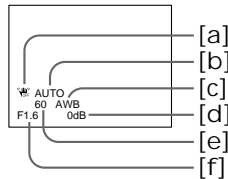

- [a] SteadyShot OFF indicator
- [b] Exposure mode/PROGRAM AE mode indicator
- [c] White balance indicator
- [d] Gain indicator
- [e] Shutter speed indicator
- [f] Aperture value

To not display the various settings

Set DATA CODE to DATE in the menu settings (p. 107).

The display changes as follows:

date/time ↔ no indicator

Recording data

Recording data is your camcorder's information when you have recorded something. In CAMERA mode, the recording data will not be displayed.

When you use the data code function, "--- - ----" (date) or "-- : -- : --" (time) appears if:

- A blank portion of the tape is being played back.
- The tape is unreadable due to tape damage or noise.
- The tape was recorded by the camcorder without the date and time set.

Data code

When you connect your camcorder to the TV, the data code also appears on the TV screen (p. 30).

Note on the date/time indicator

Recording date/time is not displayed during shooting, however, it is automatically recorded on the tape. You can check the recording date/time during playback by pressing DATA CODE.

If the exposure adjustment is set to minimum
"CLOSE" is displayed at the location of the aperture value.

Various playback modes

To operate video control buttons, set the POWER switch to VCR.

To view a still picture (playback pause)

Press **II** during playback. To resume normal playback, press **▶** or **II**.

To advance the tape

Press **▶▶** in stop mode. To resume normal playback, press **▶**.

To rewind the tape

Press **◀◀** in stop mode. To resume normal playback, press **▶**.

To change the playback direction

Press **<** on the Remote Commander during playback to reverse the playback direction.

To resume normal playback, press **▶**.

To locate a scene monitoring the picture (picture search)

Keep pressing **◀◀** or **▶▶** during playback. To resume normal playback, release the button.

To monitor the picture at high-speed while advancing or rewinding the tape (skip scan)

Keep pressing **◀◀** while rewinding or **▶▶** while advancing the tape. To resume rewinding or advancing, release the button.

To view the picture at slow speed (slow playback)

Press **▶** during playback. For slow playback in the reverse direction, press **<** on the Remote Commander, then press **▶**. To resume normal playback, press **▶**.

To view the picture at double speed

Press **×2** on the Remote Commander during playback. For double speed playback in the reverse direction, press **<**, then press **×2** on the Remote Commander. To resume normal playback, press **▶**.

To view the picture frame-by-frame

Press **II▶** on the Remote Commander in playback pause mode. For frame-by-frame playback in the reverse direction, press **◀II**. To resume normal playback, press **▶**.

To search the last scene recorded (END SEARCH)

Press **END SEARCH** in stop mode. The last five seconds of the recorded portion plays back and stops.

In various playback modes

- Sound is muted.
- The previous picture may remain as a mosaic image during playback.

When the playback pause mode lasts for five minutes

Your camcorder automatically enters the stop mode. To resume playback, press **▶**.

Slow playback

Slow playback can be performed smoothly on your camcorder, however, this function does not work for a signal output through the **⏏** DV IN/OUT jack.

When you play back a tape in reverse

Horizontal noise may appear at the center, or the top and bottom of the screen. This is not a malfunction.

If you insert the mini DV cassette recorded in a PAL system

The camcorder automatically identify the system, and playback starts. You can only view the picture on your camcorder. (Quasi PAL playback)

Viewing the recording on TV

Connect your camcorder to your TV or VCR with the A/V connecting cable supplied with your camcorder to watch the playback picture on the TV screen. You can operate the video control buttons in the same way as when you monitor playback pictures on the LCD screen. When monitoring the playback picture on the TV screen, we recommend that you power your camcorder from a wall outlet using the AC power adaptor (p. 13). Refer to the operating instructions of your TV or VCR.

Open the jack cover. Connect your camcorder to the TV using the A/V connecting cable supplied with your camcorder. Then, set the TV/VCR selector on the TV to VCR.

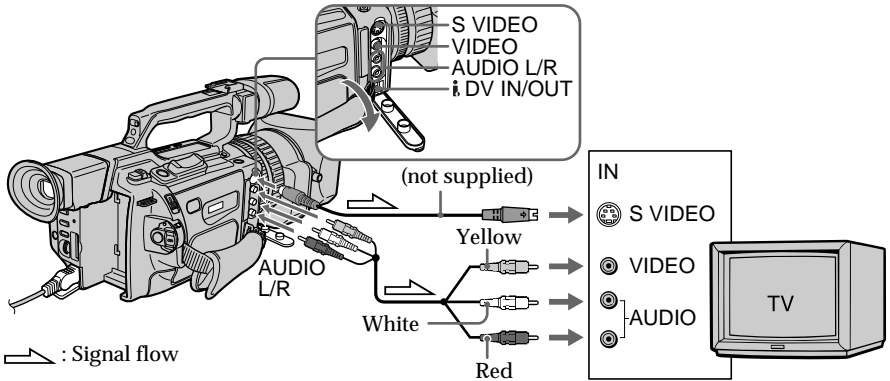

If your TV is connected to a VCR

Connect your camcorder to the line input on the VCR by using the A/V connecting cable supplied with your camcorder. Set the input selector on the VCR to LINE.

If your TV or VCR is a monaural type

Connect the yellow plug of the A/V connecting cable to the video input jack and only the white plug to the audio input jack on the VCR or the TV. The red plugs are not used.

If your TV or VCR has an S video jack

Connect using an S video cable (not supplied) to obtain high-quality pictures. With this connection, you do not need to connect the yellow (video) plug of the A/V connecting cable. Connect the S video cable (not supplied) to the S video jacks on both your camcorder and the TV or the VCR. This connection produces higher quality DV format pictures.

When you adjust the TV screen

If you monitor the shooting picture, not the playback picture, set COLOR BAR to ON in the menu settings (p. 107). The color bar is displayed on the TV screen.

Recording a still image on a tape – Tape Photo recording

You can record still images on mini DV tapes with all the pixels in the progressive mode. See page 34 for details. This mode is useful when you print images using a video printer (not supplied).

Besides the operation described here, your camcorder can record still images on a “Memory Stick” (p. 120).

- (1) In standby mode, keep pressing PHOTO lightly until a picture freezes. The CAPTURE indicator appears. Recording does not start yet.

To change the image, release PHOTO, select an image again, and then press and hold PHOTO lightly.

- (2) Press PHOTO deeper.

The still image on the LCD screen or in the viewfinder is recorded for about seven seconds. The sound during those seven seconds is also recorded.

The still image is displayed on the LCD screen or in the viewfinder until recording is completed.

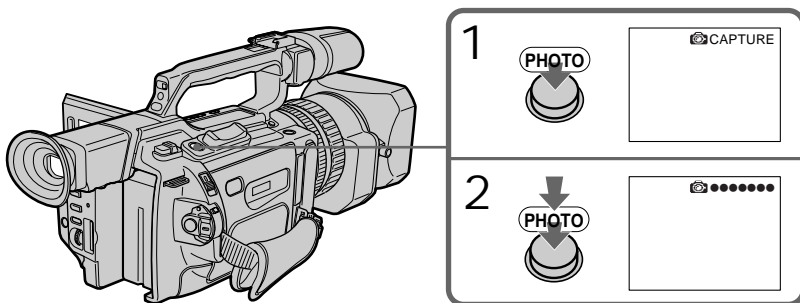

The number of still images recordable on a mini DV cassette

You can record about 510 images in SP mode and about 765 images in LP mode on a 60-minute cassette.

Notes

- During tape photo recording, you cannot change the mode or setting.
- The PHOTO button does not work:
 - While the fader function is set or in use.
 - While the digital effect function is set or in use.
- Do not shake the camcorder during tape photo recording. The recorded image may be blurred.

To do tape photo recording using the Remote Commander



Press PHOTO on the Remote Commander. Your camcorder immediately records an image on the LCD screen or in the viewfinder.

When you do tape photo recording during normal CAMERA recording

You cannot check an image on the LCD screen or in the viewfinder by pressing PHOTO lightly. Press PHOTO deeper. The still image is then recorded for about seven seconds and your camcorder returns to standby mode.



Self-timer tape photo recording

You can make a tape photo recording with the self-timer. This mode is useful when you want to record yourself. You can also use the Remote Commander.

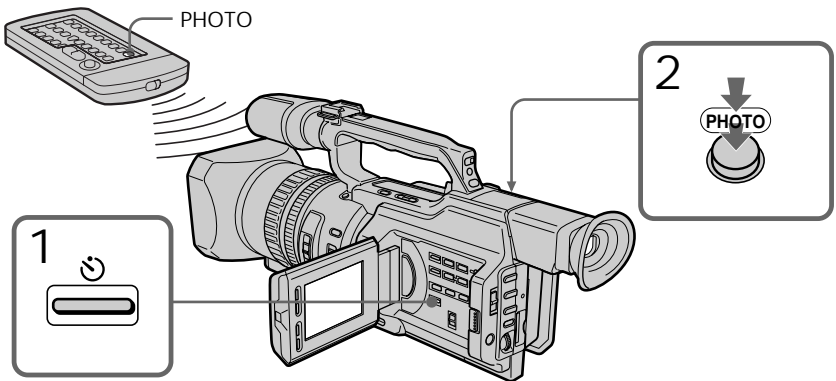
- (1) Press  (self-timer) in standby mode. The  (self-timer) indicator appears on the LCD screen or in the viewfinder.
- (2) Press PHOTO deeply.
Self-timer starts counting down from 10 with a beep sound. In the last two seconds of the countdown, the beep sound gets faster, then recording starts automatically.



To cancel self-timer recording

Press  (self-timer) so that the  indicator disappears from the LCD or viewfinder screen while your camcorder is in standby mode. You cannot cancel the self-timer recording using the Remote Commander.

Note

The self-timer recording mode is automatically canceled when:

- Self-timer tape photo recording is finished.
- The POWER switch is set to OFF (CHG) or VCR.

Recording a still image on a tape – Tape Photo recording

Printing the still image

You can print a still image by using a video printer (not supplied). Connect with the video printer using the A/V connecting cable supplied with your camcorder. Connect the yellow plugs of the cable to the video input of the video printer and the VIDEO jack on your camcorder. Refer to the operating instructions of the video printer as well.

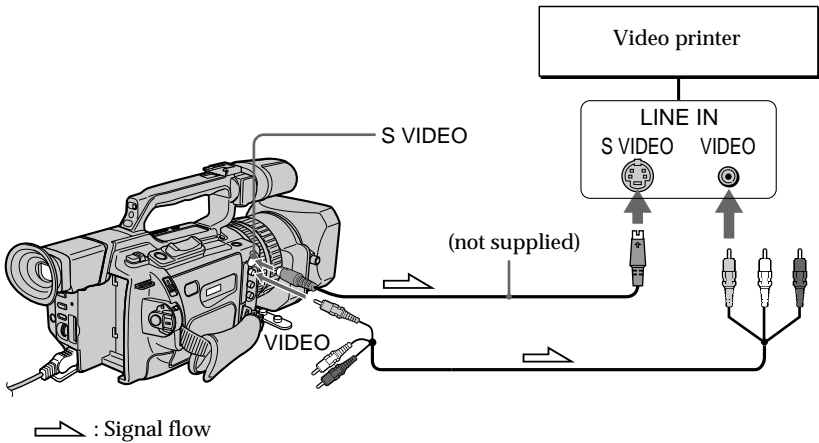

If the video printer is equipped with an S video input
Use an S video connecting cable (not supplied). Connect it to the S VIDEO jack on your camcorder and the S video input of the video printer.

Shooting with all the pixels – PROG. SCAN

When you handle the digital images on your PC, set PROG. SCAN to ON before shooting. You can record the images on a mini DV tape with higher resolution. Since the image taken in progressive mode would be stabilized even in pause mode, it is especially useful when you analyze high-speed actions such as sports scenes.

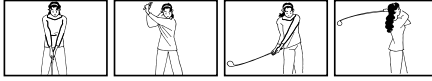

- (1) Press MENU to display the menu in standby mode.
- (2) Turn the SEL/PUSH EXEC dial to select , then press the dial.
- (3) Turn the SEL/PUSH EXEC dial to select PROG. SCAN, then press the dial.
- (4) Turn the SEL/PUSH EXEC dial to select ON, then press the dial.
- (5) Press MENU to erase the menu display. The PROG. SCAN indicator lights up.

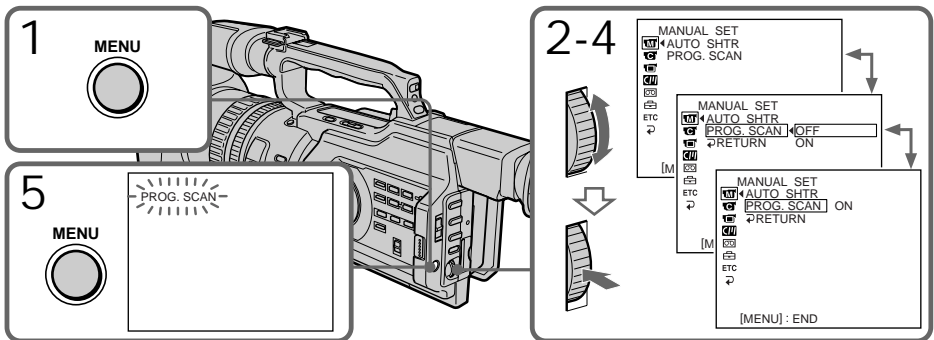

To return to normal mode
Select OFF in step 4, then press the SEL/PUSH EXEC dial.

Note on the progressive mode

A normal TV broadcast divides the screen into two finer fields and displays them in turns every 1/60 of a second (Interlace format). Thus, the actual image displayed in an instant covers only half of the apparent image area. Displaying the whole image simultaneously on a full screen is called displaying with all the pixels. In this mode, the resolution of the still picture is clearer than in the normal mode. This camcorder takes in an image every 1/15 of a second, which may cause the image of a moving object to go out of focus. This camcorder is originally programmed to record in the normal TV format.

When shooting under fluorescent light

When shooting in progressive mode under fluorescent light or light bulbs, a rare phenomenon may happen in which the screen lights up brightly (Flicker phenomenon). This is not a malfunction. If you want to stop this phenomenon, set PROG. SCAN to OFF in the menu settings.

On digital zooming

You cannot use digital zooming in this mode.

Using the guide frame

You can easily make the picture be on a horizontal line using the guide frame. The guide frame is not recorded.

- (1) Press MENU to display the menu in standby mode.
- (2) Turn the SEL/PUSH EXEC dial to select , then press the dial.
- (3) Turn the SEL/PUSH EXEC dial to select GUIDEFRA, then press the dial.
- (4) Turn the SEL/PUSH EXEC dial to select ON, then press the dial.
- (5) Press MENU to erase the menu display. The guide frame is displayed on the LCD screen or in the viewfinder.

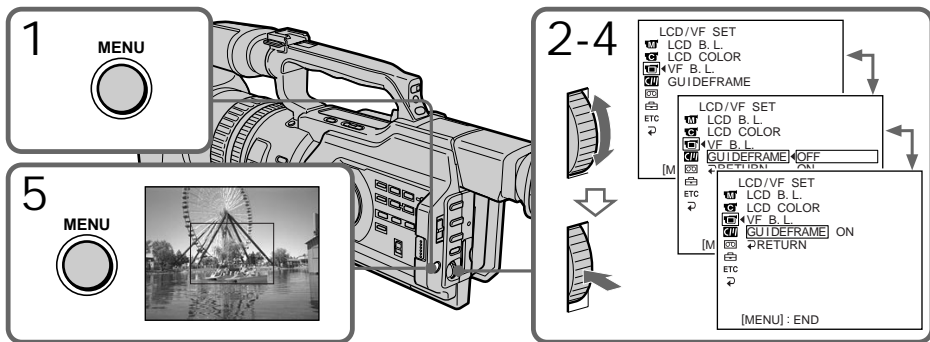

To clear the guide frame

Select OFF in step 4, then press the SEL/PUSH EXEC dial or simply press DISPLAY.

Note

The guide frame indicates only a rough level. The size and position of the guide frame do not affect the setting of the camcorder.

If you set GUIDEFRA to ON

The other screen indicators are also displayed on the LCD screen.

Using the wide mode

You can record a 16:9 wide picture to watch on a 16:9 wide-screen TV (16:9WIDE). Black bands appear on the LCD screen or in the viewfinder during recording in 16:9WIDE mode [a]. The picture during playback on a normal TV [b] or on a wide-screen TV [c] is compressed in the widthwise direction. If you set the screen mode of the wide-screen TV to the full mode, you can watch pictures of normal images [d].

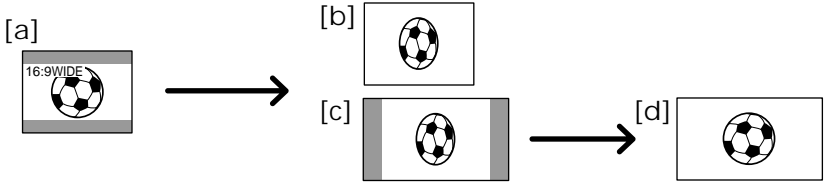

In standby mode, set 16:9WIDE to ON in  in the menu settings (p. 107).

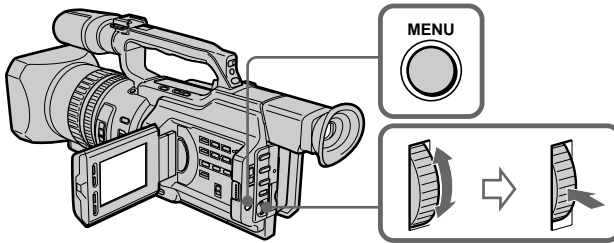

To cancel the wide mode

Set 16:9WIDE to OFF in the menu settings (p. 107).

In wide mode, you cannot select the following modes:

- Old movie
- Progressive mode

Connection to a TV

Pictures recorded in 16:9WIDE mode automatically appear on the TV screen at full size when you connect your camcorder to a TV that is compatible with the video ID (ID-1/ID-2) system and when you connect to the S video input jack on a TV.

ID-1 system

The ID-1 system sends aspect ratio information (16:9, 4:3, or letter box) using video signals. If you connect a TV compatible with the ID-1 system, the screen size is automatically selected.

ID-2 system

The ID-2 system sends a copyright protection signal with ID-1 signals inserted between video signals when you connect your camcorder to other equipment using an A/V connecting cable.

During recording

You cannot operate the wide mode function. When you cancel the wide mode, set your camcorder to the standby mode and then set 16:9WIDE to OFF in the menu settings.

Using the fader function

You can fade the picture in or out to give your recording a professional appearance.

[a] STBY REC

FADER

OVERLAP*

WIPE*

DOT* (Random)

* Fade in only

[b] STBY REC

Advanced Recording Operations

MONOTONE

When fading in, the picture gradually changes from black-and-white to color.
When fading out the picture gradually changes from color to black-and-white.

Using the fader function

- (1) When fading in [a]
In standby mode, press FADER until the desired fader indicator flashes.
When fading out [b]
In recording mode, press FADER until the desired fader indicator flashes.
The indicator changes as follows:
FADER → MONOTONE → OVERLAP → WIPE → DOT → no indicator
The last selected fader mode is indicated first.
- (2) Press START/STOP. After the fade in/out is carried out, your camcorder automatically returns to the normal mode.

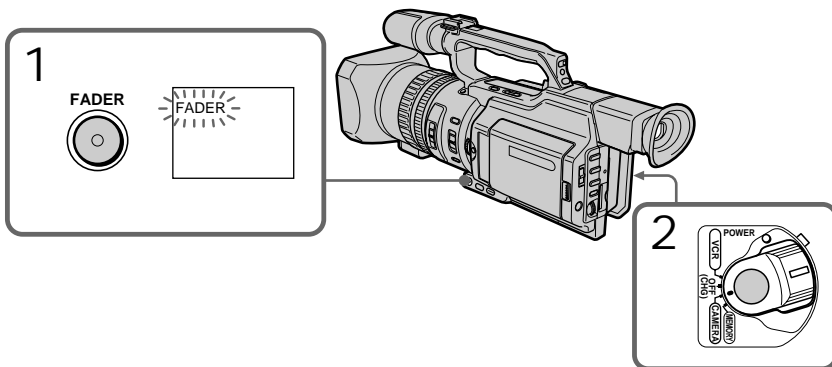

To cancel the fader function
Press FADER until the indicator disappears.

Note

You cannot use the following functions while using the fader function, and vice versa:

- Digital effect
- Low lux mode of PROGRAM AE (Only in OVERLAP, WIPE, or DOT mode)
- Tape Photo recording
- Interval recording
- Cut recording

When the OVERLAP, WIPE, or DOT indicator appears

Your camcorder automatically stores the image recorded on a tape. As the image is being stored, the fader indicator flashes fast, and the playback picture appears.

Using special effects – Picture effect

You can digitally process images to obtain special effects like those in films or on TV.

NEG. ART [a] : The color and brightness of the picture is reversed.

SEPIA : The picture gets sepia-toned.

B&W : The picture appears in monochrome (black-and-white).

SOLARIZE [b] : The light intensity is emphatic, and the picture looks like an illustration.

SLIM [c] : The picture expands vertically.

STRETCH [d] : The picture expands horizontally.

[a]



[b]



[c]



[d]



- (1) In standby or recording mode, press PICTURE EFFECT.
- (2) Turn the SEL/PUSH EXEC dial to select the desired picture effect mode.
The picture effect indicator changes as follows:
NEG. ART ↔ SEPIA ↔ B&W ↔ SOLARIZE ↔ SLIM ↔ STRETCH

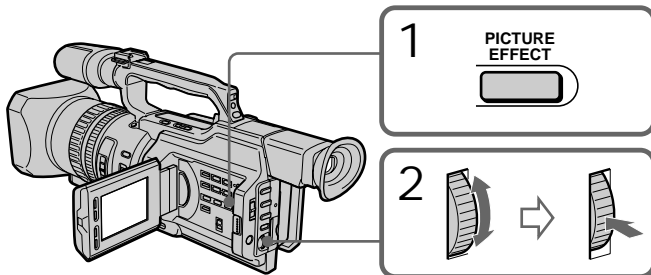

To cancel the picture effect function

Press PICTURE EFFECT so that the indicator disappears.

While using the picture effect function

You cannot select the old movie mode.

When you turn the power off

The picture effect function will be automatically canceled.

When PROG. SCAN is set to ON in the menu settings

You cannot select SLIM and STRETCH.

Using special effects – Digital effect

You can add special effects to recorded pictures using the various digital functions. The sound is recorded normally.

STILL

You can record a still image so that it is superimposed on a moving picture.

FLASH (FLASH MOTION)

You can record still images successively at constant intervals.

LUMI. (LUMINANCEKEY)

You can swap a brighter area in a still image with a moving picture.

TRAIL

You can record the picture so that an incidental image like a trail is left.

OLD MOVIE

You can add an old movie type atmosphere to pictures. The black bands appear on the upper and lower of the screen to change the virtual screen size to the cinemascope size, and the picture effect is set to SEPIA.



Using special effects – Digital effect

- (1) In standby or recording mode, press DIGITAL EFFECT. The digital effect indicator appears.
- (2) Turn the SEL/PUSH EXEC dial to select the desired digital effect mode.
The digital effect indicator changes as follows:
STILL ↔ FLASH ↔ LUMI. ↔ TRAIL ↔ OLD MOVIE
- (3) Press the SEL/PUSH EXEC dial. The indicator lights up and the bar appears.
In STILL and LUMI. modes, the still image is stored in memory.
- (4) Turn the SEL/PUSH EXEC dial to adjust the effect.

Items to be adjusted

STILL	The rate of the still image you want to superimpose on the moving picture
FLASH	The interval of flash motion
LUMI.	The color scheme of the area in the still image which is to be swapped with a moving picture
TRAIL	The time until the incidental image vanishes
OLD MOVIE	No adjustment necessary

The longer the bar on the screen, the stronger the digital effect. The bar appears in the following modes: STILL, FLASH, LUMI. and TRAIL.

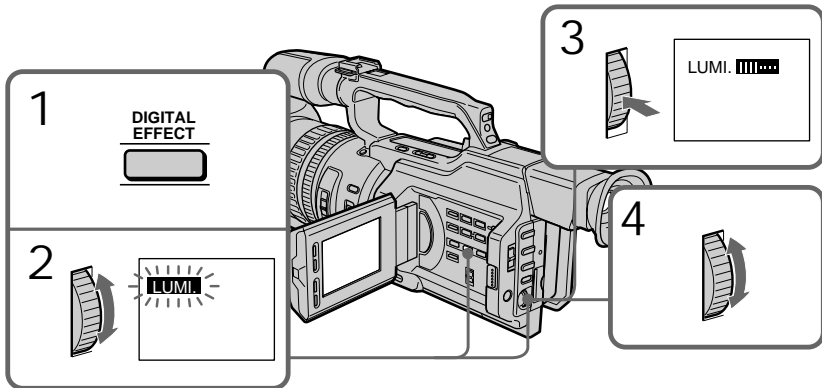

To cancel the digital effect

Press DIGITAL EFFECT. The digital effect indicator disappears.

Using special effects – Digital effect

Notes

- The following functions do not work in digital effect mode:
 - Fader
 - Low lux mode of PROGRAM AE
 - Tape Photo recording
 - Shutter speed (1/30 or smaller) adjustment
- The following functions do not work in old movie mode:
 - Wide mode
 - Picture effect
 - PROGRAM AE
 - Spot light mode
 - Shutter speed adjustment

When you turn the power off

The digital effect function will be automatically canceled.

Shooting with manual adjustment

Under normal conditions, this unit automatically makes various adjustments as it shoots. However, you can adjust the following functions manually to suit your preference.

Functions you can adjust by setting the AUTO LOCK selector to the center (auto lock release) position

Brightness (exposure), shutter speed, white balance, and PROGRAM AE

Functions you can adjust in menu settings

Deactivating the SteadyShot

Functions you can adjust by using other selectors/rings

ND filter, zebra pattern, focus, and zoom

The following describes how to adjust all the functions mentioned above except white balance (p. 49), PROGRAM AE (p. 55), focus (p. 58), and zoom (p. 20).

AUTO LOCK selector

Set the selector as shown below to maintain or release the settings of the functions.

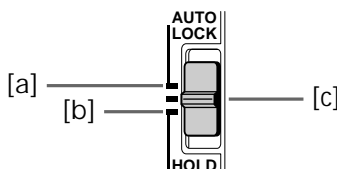

AUTO LOCK [a]

Select this position to let the unit adjust all the functions automatically.

HOLD [b]

Select this position after setting the functions manually to maintain the settings.

Manual position (AUTO LOCK release) [c]

Select this position to adjust the functions listed above manually.

If you use the video flash light (not supplied)

We recommend that you set the AUTO LOCK selector to AUTO LOCK.

Note

When you manually adjust the exposure during backlight or spot light mode, the backlight or spot light function will be automatically canceled.

Shooting with manual adjustment

Adjusting exposure

Adjust the exposure manually under the following cases.

[a]



[b]



[a]

- The background is too bright (back lighting)
- Insufficient light: most of the picture is dark

[b]

- Bright subject and dark background
- To record the darkness faithfully

- (1) Set the AUTO LOCK selector to the center (auto lock release) position while the camcorder is in standby, recording, or memory mode.
- (2) Press EXPOSURE. The exposure indicator appears on the LCD screen or in the viewfinder.
- (3) Turn the EXPOSURE dial to adjust the exposure.
As you turn the dial, the iris value changes between OPEN and CLOSE and the gain value changes between 0 dB and 18dB.
To brighten the picture, adjust the level to the + side.

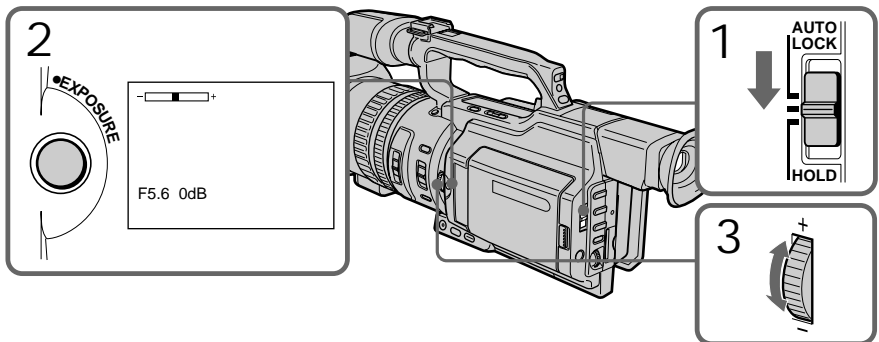

To return to automatic exposure mode

Set the AUTO LOCK selector to AUTO LOCK or press EXPOSURE. The exposure indicator disappears from the LCD or viewfinder screen.

If you press PROGRAM AE when adjusting the exposure manually
The exposure comes back to automatic adjustment again.

When you focus in telephoto
You cannot choose F1.6 and F2.0.

Adjusting the shutter speed

- (1) Set the AUTO LOCK selector to the center (auto lock release) position while the camcorder is in standby, recording, or memory mode.
- (2) If the PROGRAM AE indicator is lit, press PROGRAM AE repeatedly until the indicator disappears from the LCD or viewfinder screen.
- (3) Press SHUTTER SPEED. The shutter speed indicator appears on the LCD screen or in the viewfinder.
- (4) Turn the SEL/PUSH EXEC dial to select the desired speed. The available shutter speed ranges from 1/4 to 1/10000. As you turn the dial, the shutter speed changes as follows:
1/4 ↔ 1/8 ↔ 1/15 ↔ 1/30 ↔ ... ↔ 1/4000 ↔ 1/6000 ↔ 1/10000
To increase the shutter speed, select a smaller setting (large value indicator on the LCD screen or in the viewfinder).

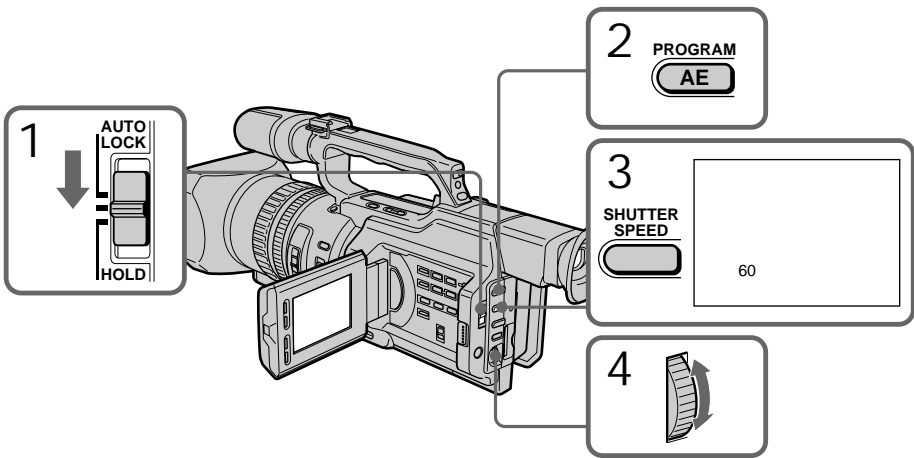

To return to automatic shutter speed mode

Set the AUTO LOCK selector to AUTO LOCK or press SHUTTER SPEED. The shutter speed indicator disappears from the LCD or viewfinder screen.

When shooting at slow shutter speed

At slow shutter speed, automatic focus may be lost. Use a tripod and adjust the focus manually.

When shooting under fluorescent light or light bulbs

When shooting under fluorescent light or light bulbs, a rare phenomenon may happen in which the screen lights up brightly depending on the shutter speed (Flicker phenomenon).

If you set the shutter speed value to 1/30 or smaller

You cannot use the spot light (p. 23) and digital effect (p. 40) functions.

Shooting with manual adjustment

Using the ND filter

Using the ND filter (the ND filter 1 setting corresponds to 1/4 of the quantity of light and the ND filter 2 setting corresponds to 1/32 of the quantity of light), you can record a picture clearly by adjusting light amounts, even if you shoot under too bright conditions.

When the ND1 or ND2 indicator flashes on the LCD screen or in the viewfinder

The ND filter is necessary.

When ND 1 flashes, set the ND FILTER selector to 1 so that the ND 1 indicator lights up on the LCD screen or in the viewfinder.

When ND 2 flashes, set the ND FILTER selector to 2 so that the ND 2 indicator lights up on the LCD screen or in the viewfinder.

When ND OFF flashes on the LCD screen or in the viewfinder

The ND filter is not necessary. Set the ND FILTER selector to OFF so that the indicator disappears from the LCD or viewfinder screen.

The ND filter is now deactivated.

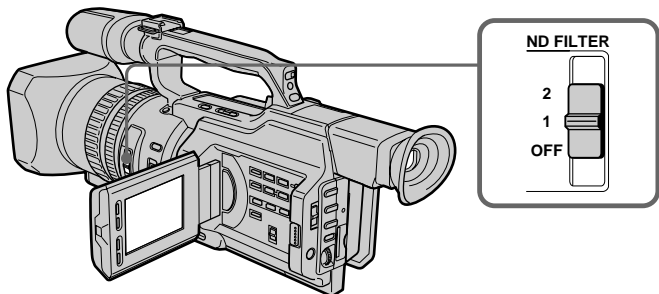

Note

If you set the ND FILTER selector to another positions during recording, the picture may be blurred or audio noise may occur. We recommend that you check the position of the ND FILTER selector before shooting.

If you use the video flash light (not supplied)

Set the ND FILTER selector to OFF when you use the flash.

Shooting with manual adjustment

Shooting with the zebra pattern

You can set the camcorder to display a zebra pattern (diagonal stripes) in the portion of the picture on the LCD screen or in the viewfinder with a subject whose brightness exceeds a certain level. The portion of the picture where zebra pattern appears is an area of high brightness and overexposure. You can check the picture level of a subject by displaying the zebra pattern. Use the zebra pattern as a guide for adjusting the exposure and shutter speed so that you can get the desired picture.

Set the ZEBRA selector to 70 or 100 in standby or memory mode.

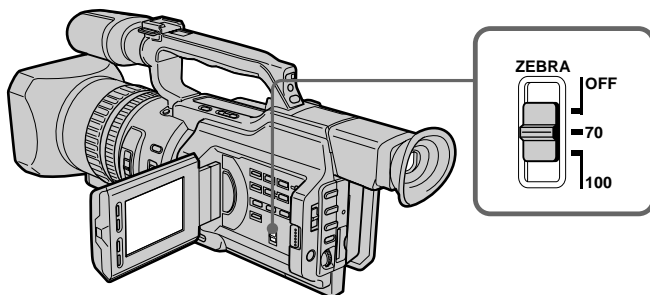

Setting	Meaning
70	The zebra pattern appears in the portion of the picture on the LCD screen or in the viewfinder with a subject whose brightness is about 70 IRE.
100	The zebra pattern appears in the portion of the picture on the LCD screen or in the viewfinder with a subject whose brightness exceeds more than 100 IRE.
OFF	The zebra pattern does not appear on the LCD screen or in the viewfinder.

To erase the zebra pattern

Set the ZEBRA selector to OFF.

Note on shooting with the zebra pattern

Even though you see the zebra pattern on the LCD screen or in the viewfinder, the zebra pattern is not recorded.

Shooting with manual adjustment

Releasing the SteadyShot function

When the SteadyShot function is working, the camcorder compensates for camera-shake.

You can release the SteadyShot function when you do not need to use it. The  indicator appears on the LCD screen or in the viewfinder. Do not use the SteadyShot function when shooting a stationary object with a tripod.

- (1) Press MENU to display the menu in standby or memory mode.
- (2) Turn the SEL/PUSH EXEC dial to select , then press the dial.
- (3) Turn the SEL/PUSH EXEC dial to select STEADYSHOT, then press the dial.
- (4) Turn the SEL/PUSH EXEC dial to select OFF, then press the dial.
- (5) Press MENU to erase the menu display.

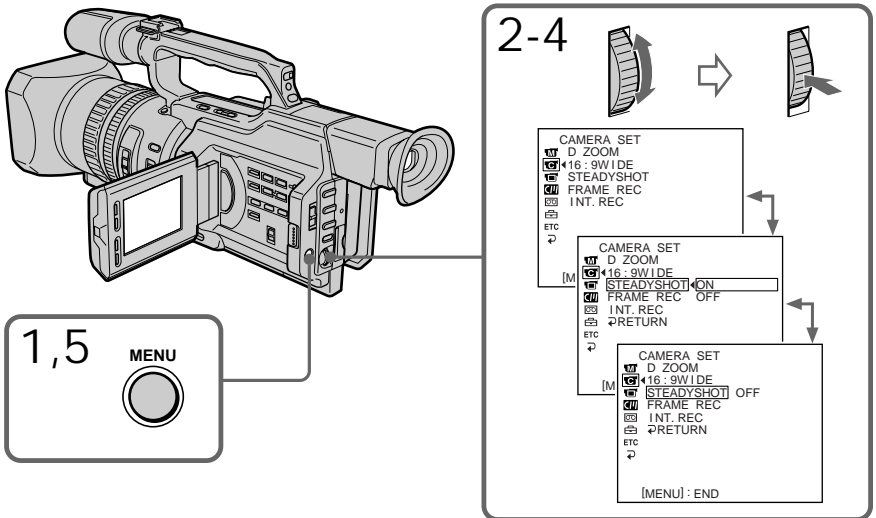

To activate the SteadyShot function again
Select ON in step 4, then press the SEL/PUSH EXEC dial.

Notes on the SteadyShot function

- The SteadyShot function will not correct excessive camera-shake.
- If you use a tele conversion lens (not supplied) or a wide conversion lens (not supplied), these lens may influence the SteadyShot function.

Adjusting the white balance

White balance adjustment makes white subjects look white and allows more natural color balance for camera recording. Normally, white balance is automatically adjusted. You can obtain better results by adjusting the white balance manually when lighting conditions change quickly or when recording outdoors: e.g., neon signs, fireworks.

- (1) Set the AUTO LOCK selector to the center (auto lock release) position while the camcorder is in standby, recording, or memory mode.
- (2) Press WHT BAL. The white balance indicator appears on the LCD screen or in the viewfinder.
- (3) Turn the SEL/PUSH EXEC dial to select the appropriate white balance mode under the following conditions. As you turn the dial, the display changes as follows:

☑ (One-push white balance) ↔ ☀ (Outdoor) ↔ ☹ (Indoor)

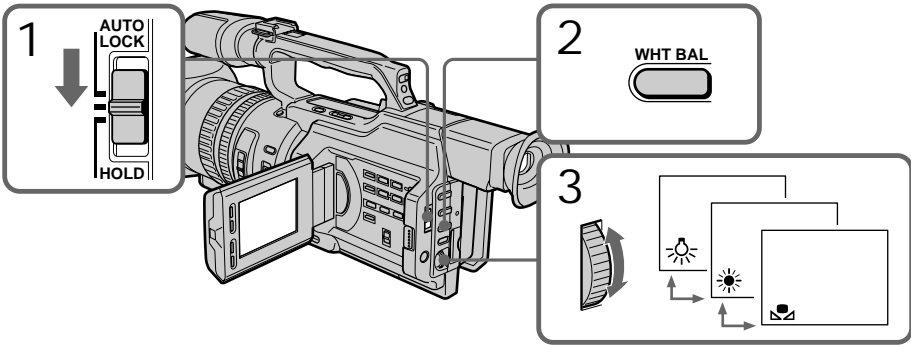

Indicator	Shooting conditions
☑	<ul style="list-style-type: none"> • Adjusting the white balance according to the light source. This operation is not available during recording. Follow the procedure described on the next page to adjust the setting again.
☀ (Outdoor)	<ul style="list-style-type: none"> • Recording a sunset/sunrise, just after sunset, just before sunrise, neon signs, or fireworks • Under a color matching fluorescent lamp
☹ (Indoor)	<ul style="list-style-type: none"> • Lighting condition changes quickly • Too bright a place such as a photography studio • Under sodium lamps or mercury lamps

Adjusting the white balance

If you have selected  in step 3

When you set the white balance to one-push white balance mode, the setting is locked and maintained even if lighting conditions change. You can achieve recording with natural colors without the image being affected by ambient light.

(With the  indicator on the screen)

(1) Shoot a white object such as paper fully.



(2) Press the SEL/PUSH EXEC dial.

The  indicator flashes quickly. When the white balance has been adjusted and stored in the memory, the indicator stops flashing. The setting will be maintained even if the battery is detached.

To return to automatic adjustment

Set the AUTO LOCK selector to AUTO LOCK or press WHT BAL. The white balance indicator disappears from the LCD or viewfinder screen.

Notes on white balance

- When you shoot with studio lighting or video lighting, use the  (indoor) mode.
- When you shoot with fluorescent lighting, readjust the white balance using the  (one-push white balance) mode, or use the automatic white balance mode. If you use the  (indoor) mode, white balance may not be adjusted appropriately.

Shooting when lighting conditions have changed

- When lighting conditions have changed, readjust the white balance while the camcorder is in standby mode.
- In automatic white balance mode, point your camcorder at a white subject for about 10 seconds after setting the POWER switch to CAMERA to get a better adjustment when:
 - You detach the battery for replacement.
 - You bring your camcorder outdoors from the interior of a house, or vice versa.

If the  indicator does not stop flashing after you press the SEL/PUSH EXEC dial The white balance cannot be set. Use the automatic white balance mode.

Adjusting recording level manually – Sound recording level

You can adjust the recording sound level. Use headphones to monitor the sound when you adjust it.

Setting up the menu

- (1) Set the POWER switch to CAMERA or VCR.
- (2) Press MENU to display the menu.
- (3) Turn the SEL/PUSH EXEC dial to select , then press the dial.
- (4) Turn the SEL/PUSH EXEC dial to select MIC LEVEL, then press the dial.
- (5) Turn the SEL/PUSH EXEC dial to select MANUAL, then press the dial.
- (6) Press MENU to erase the menu display.

Adjusting the recording level

- (7) Press AUDIO LEVEL to display the recording level adjustment display in standby or recording mode.
- (8) Turn the SEL/PUSH EXEC dial to adjust the recording level.

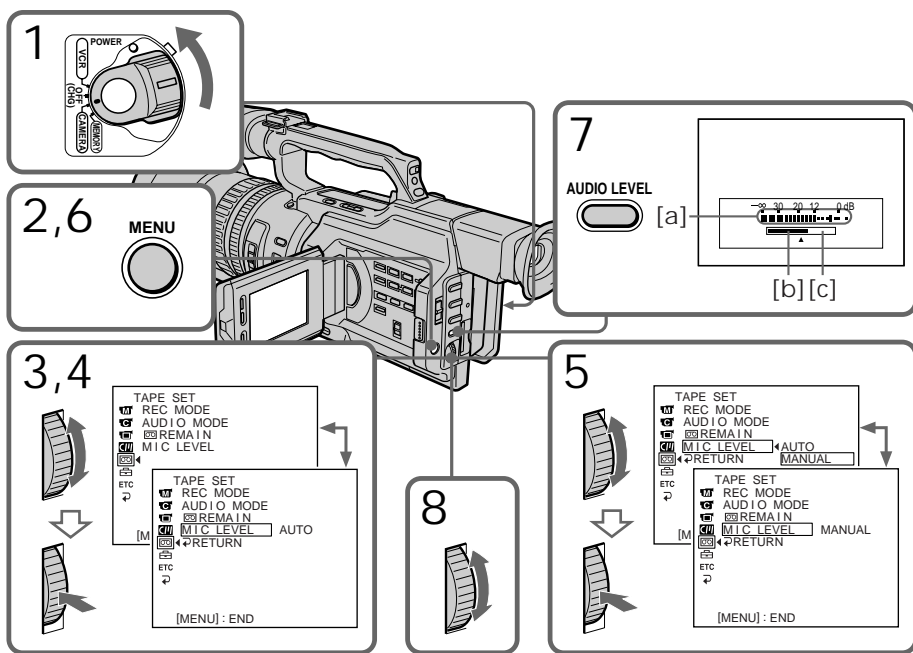

[a] Recording level meter

[b] Decreases the recording level

[c] Increases the recording level

To clear the recording level adjustment display
Press AUDIO LEVEL again.

To adjust the recording level automatically
Select AUTO in step 5, then press the SEL/PUSH EXEC dial.

Adjusting recording level manually – Sound recording level

Notes on the manual adjustment

- The recording level setting is retained for about five minutes after removing the battery.
- The recording level indicator appears at the lower-right on the LCD screen or in the viewfinder.

The sound input through the AUDIO L/R jacks or DV IN/OUT jack
You cannot adjust the recording level.

When MIC LEVEL is set to AUTO

You cannot adjust the recording level, however, the recording level adjustment display is displayed.

Presetting the adjustment for picture quality – Custom preset

You can preset the camcorder to record the picture with the desired picture quality. When presetting, adjust the picture by shooting a subject and checking the picture displayed on a TV using the menu settings.

- (1) Press CUSTOM PRESET to display the CUSTOM PRESET menu in standby or memory mode.
- (2) Press the SEL/PUSH EXEC dial.
- (3) Turn the SEL/PUSH EXEC dial to select SET, then press the dial.
- (4) Turn the SEL/PUSH EXEC dial to select ON, then press the dial.
- (5) Turn the SEL/PUSH EXEC dial to select the desired item, then press the dial.
- (6) Turn the SEL/PUSH EXEC dial to adjust the selected item, then press the dial.
- (7) Press CUSTOM PRESET.

The CUSTOM PRESET menu disappears and the indicator **CP** appears on the LCD screen or in the viewfinder.

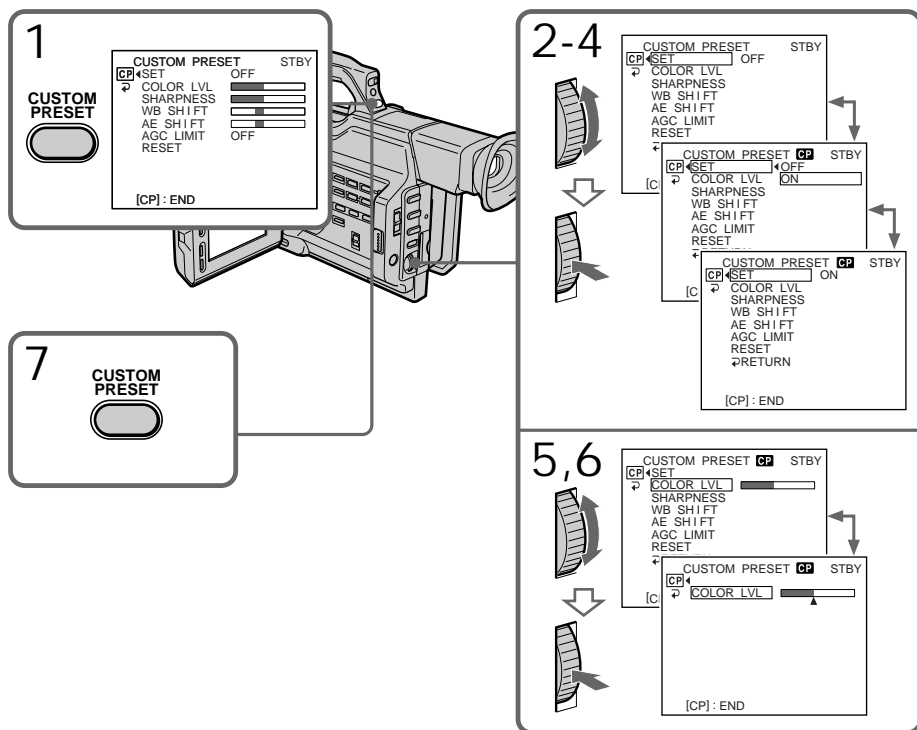

Presetting the adjustment for picture quality

Items to be adjusted

Item	Meaning	Adjustment value
COLOR LVL	Color intensity	Decreases color intensity ↔ Increases color intensity
SHARPNESS	Sharpness	Softer ↔ Sharper
WB SHIFT	White balance	Bluish ↔ Reddish
AE SHIFT	Brightness	-4 ↔ +4
AGC LIMIT	Auto Gain-limit	6 dB/12 dB/OFF
RESET	Sets items above to the default settings.	

To cancel using the custom preset

Select OFF in step 4, then press the SEL/PUSH EXEC dial.

To return to the standard setting



Select OK from the RESET item in step 5, then press the SEL/PUSH EXEC dial. To cancel, select CANCEL, then press the SEL/PUSH EXEC dial.

To check the custom preset setting

Press CUSTOM PRESET while the camcorder is in standby, recording or memory mode.

The custom preset setting appears on the LCD screen or in the viewfinder.

Once you adjust AE shift

The  -4 to  +4 indicator is displayed on the LCD screen or in the viewfinder. The number varies corresponding to the AE shift level.

About the AGC Limit

When adjusting the exposure manually, the level of the gain is up to 18 dB (OFF).

When you preset the desired picture quality in CAMERA or memory mode

The preset is only available in each mode you preset. If you want to use a preset both in CAMERA and memory modes, you have to preset in each mode.

Using the PROGRAM AE function

You can select from five PROGRAM AE (Auto Exposure) modes to suit your shooting situation, referring to the following.

Selecting the best mode

Select a proper PROGRAM AE mode referring to the following description.



A: Aperture priority mode

Selecting the aperture to determine the desired depth of field. Gain and shutter speed are automatically set in combination with the aperture value to maintain appropriate exposure.

S: Shutter speed priority mode

Selecting the shutter speed manually. The exposure value changes in accordance with the selected shutter speed.

Sports lesson mode

Capturing high-speed action in sports such as golf or tennis

Sunset & Moon mode

Recording sunset, night views, fireworks or neon signs

Low lux mode

For recording a subject in insufficient light. Subject becomes bright.

Using the PROGRAM AE function

Using the PROGRAM AE function

- (1) Set the AUTO LOCK selector to the center (auto lock release) position while the camcorder is in standby, recording, or memory mode.
- (2) Press PROGRAM AE. The PROGRAM AE indicator appears on the LCD screen or in the viewfinder.
- (3) Turn the SEL/PUSH EXEC dial to select the desired PROGRAM AE mode. The PROGRAM AE mode changes as follows:
Aperture priority mode ↔ Shutter speed priority mode ↔ Sports lesson mode ↔ Sunset & Moon mode ↔ Low lux mode
When you select the aperture priority mode or the shutter speed priority mode, press the SEL/PUSH EXEC dial.
- (4) In aperture priority mode (AE A) or shutter speed priority mode (AE S), turn the SEL/PUSH EXEC dial to select the desired aperture value (F value) or shutter speed.
Aperture priority mode:
Turn the SEL/PUSH EXEC dial to select the desired aperture value. As you turn the dial, the F value changes between F1.6 and F11.
For a smaller aperture, select a higher value. The gain and shutter speed change in accordance with the selected aperture value.
Shutter speed priority mode:
Turn the SEL/PUSH EXEC dial to select the desired shutter speed. As you turn the dial, shutter speed changes between 1/60 and 1/10000.
For a faster shutter speed, select a smaller value indicator on the LCD screen or in the viewfinder. The gain and aperture values change in accordance with the selected shutter speed.

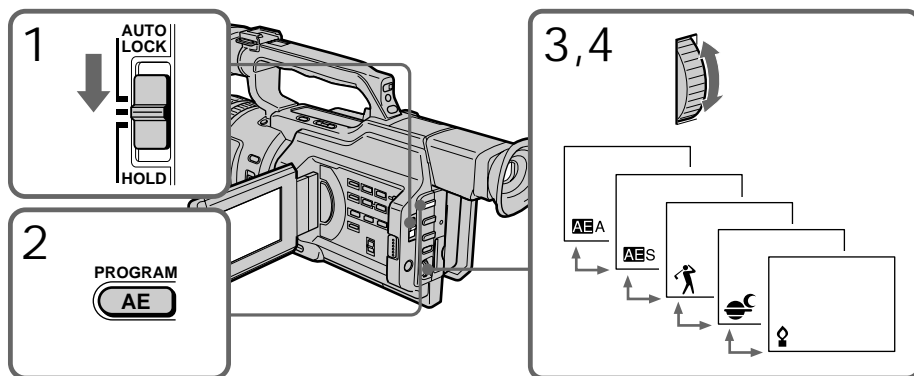

To cancel using the PROGRAM AE function

Set the AUTO LOCK selector to AUTO LOCK or press PROGRAM AE. The PROGRAM AE indicator disappears from the LCD or viewfinder screen.

Using the PROGRAM AE function

Notes

- In sports lesson mode, you cannot take close-ups. This is because your camcorder is set to focus only on subjects in the middle to far distance.
- In sunset & moon mode, your camcorder is set to focus only on distant subjects.
- The old movie mode and the shutter speed adjustment do not work in PROGRAM AE mode.
- The following functions do not work in low lux mode:
 - Digital effect
 - Overlap
 - Wipe
 - Dot
 - Spot light mode
- While shooting in memory mode, the low lux and sports lesson modes do not work. (The indicator flashes.)

If you are recording under a discharge tube such as a fluorescent lamp, sodium lamp or mercury lamp

Flickering or changes in color may occur in sports lesson mode. If this happens, turn the PROGRAM AE function off.

Even if the PROGRAM AE function is selected
You can adjust the exposure.

When you focus in telephoto
You cannot choose F1.6 and F2.0.

About the depth of field

The depth of field is the in-focus range, measured from the distance behind a subject to the distance in front. The depth of field can vary with the iris (F value) and the focal length. Lowering the F value (large iris) reduces the depth of field. Raising the F value (small iris) provides a larger depth of field. Zooming in telephoto position offers a smaller depth of field while the depth of field in the wide-angle position is greater.

The depth of field	Shallow	Deep
Iris	Near open (Low F value)	Near close (High F value)
Zoom	Telephoto (T)	Wide (W)

Focusing manually

You can gain better results by manually adjusting the focus in the following cases:

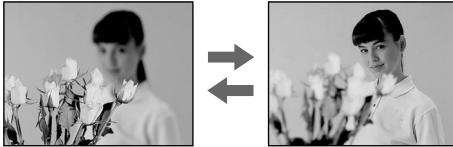

- The autofocus mode is not effective when shooting
 - subjects through glass coated with water droplets
 - horizontal stripes
 - subjects with little contrast with backgrounds such as walls and sky
- When you want to change the focus from a subject in the foreground to a subject in the background
- Shooting a stationary subject when using a tripod

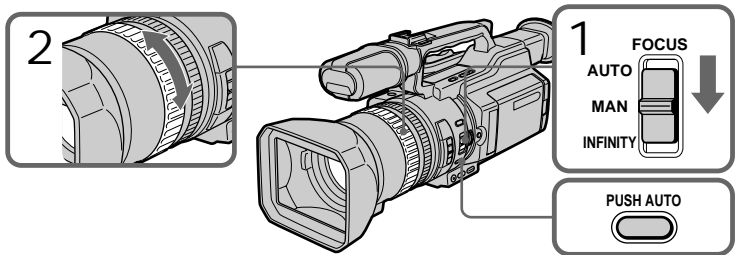

- (1) Slide FOCUS down to MANUAL in standby, recording, or memory mode. The  indicator appears on the LCD screen or in the viewfinder in recording, standby, or memory mode.
- (2) Turn the focus ring to sharpen the focus.



To return to the autofocus mode

Slide FOCUS up to AUTO to turn off the  or  indicator.

To focus in infinity

Slide FOCUS to INFINITY. The  indicator appears on the LCD screen or in the viewfinder. This function is useful when the nearer subject is focused automatically, even though you want to focus on a faraway subject.

To shoot with auto focusing momentarily

Press PUSH AUTO.

The auto focus functions while you are pressing PUSH AUTO.

Use this button to focus on one subject and then another with smooth focusing.

When you release PUSH AUTO, manual focusing resumes.

To obtain the correct focus

First, focus on a subject manually with the zoom set toward the “T” (telephoto) side, then adjust the zoom by pressing the “W” side of the lever gradually.

When you shoot close to the subject

Focus at the end of the “W” (wide-angle) position.

 changes as follows:

- ▲ when recording a distant subject.
- when the subject is too close to focus on.

Interval recording

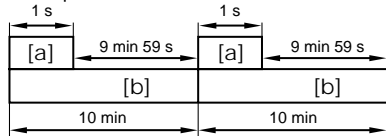

You can make a time-lapse recording by setting the camcorder to automatically record and standby sequentially. You can achieve an excellent recording for flowering, emergence, etc., with this function.

Example



[a] Recording time

[b] Waiting time

- (1) Press MENU to display the menu in standby mode.
- (2) Turn the SEL/PUSH EXEC dial to select , then press the dial.
- (3) Turn the SEL/PUSH EXEC dial to select INT. REC, then press the dial.
- (4) Turn the SEL/PUSH EXEC dial to select SET, then press the dial.
- (5) Set INTERVAL and REC TIME.
 - ① Turn the SEL/PUSH EXEC dial to select INTERVAL, then press the dial.
 - ② Turn the SEL/PUSH EXEC dial to select the desired interval time, then press the dial.
The time: 30SEC ↔ 1MIN ↔ 5MIN ↔ 10MIN
 - ③ Turn the SEL/PUSH EXEC dial to select REC TIME, then press the dial.
 - ④ Turn the SEL/PUSH EXEC dial to select the desired recording time, then press the dial.
The time: 0.5SEC ↔ 1SEC ↔ 1.5SEC ↔ 2SEC
 - ⑤ Turn the SEL/PUSH EXEC dial to select  RETURN, then press the dial twice.

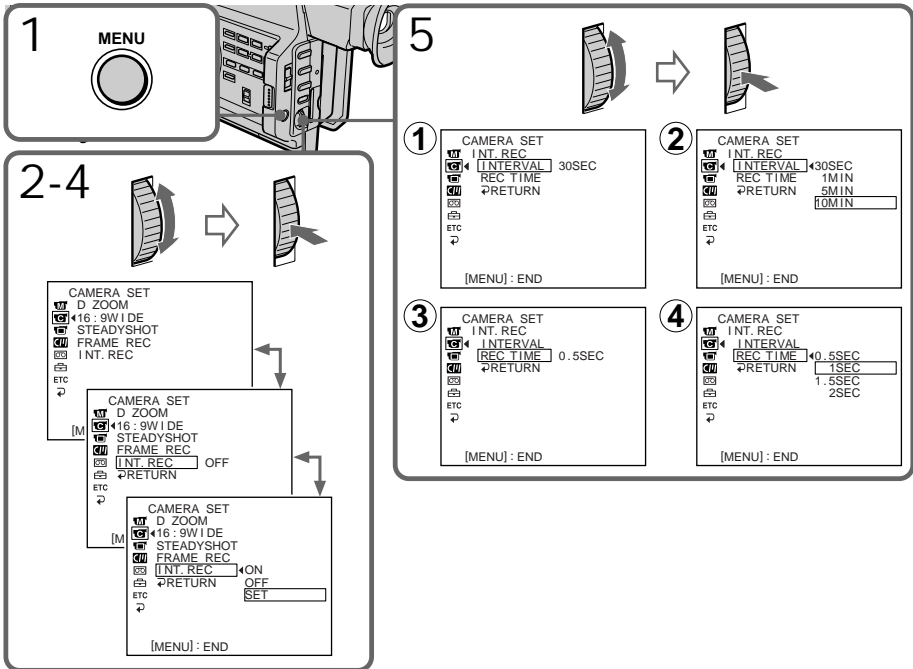

Interval recording

- (6) Turn the SEL/PUSH EXEC dial to select ON, then press the dial.
- (7) Press MENU to erase the menu display. The interval recording indicator flashes.
- (8) Press START/STOP to start interval recording. The interval recording indicator lights up.

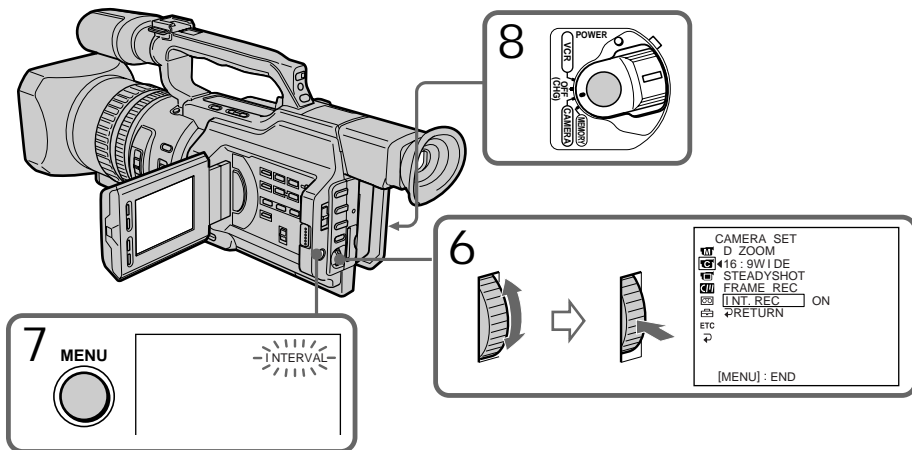

To cancel the interval recording

- Set INT. REC to OFF in the menu settings.
- Set the POWER switch to OFF (CHG), VCR or MEMORY.

To stop the interval recording momentarily and perform normal recording

Press START/STOP. You can perform normal recording only once. To cancel the normal recording, press START/STOP again.

Note on interval recording

You cannot do interval recording in memory mode.

On recording time

There may be a discrepancy in recording time of up to +/- 6 frames from the selected time.

Even if you press INDEX MARK during interval recording

You cannot mark an index.

Frame by frame recording – Cut recording

You can make a recording with a stop-motion animated effect using cut recording. To create this effect, alternately move the subject a little and make a cut recording. We recommend that you use a tripod, and operate the camcorder using the Remote Commander after step 6.

- (1) Press MENU to display the menu in standby mode.
- (2) Turn the SEL/PUSH EXEC dial to select , then press the dial.
- (3) Turn the SEL/PUSH EXEC dial to select FRAME REC, then press the dial.
- (4) Turn the SEL/PUSH EXEC dial to select ON, then press the dial.
- (5) Press MENU to erase the menu display.
The FRAME REC indicator lights up.
- (6) Press START/STOP to start cut recording. The camcorder makes a recording for about six frames, and returns to recording standby.
- (7) Move the subject, and repeat step 6.

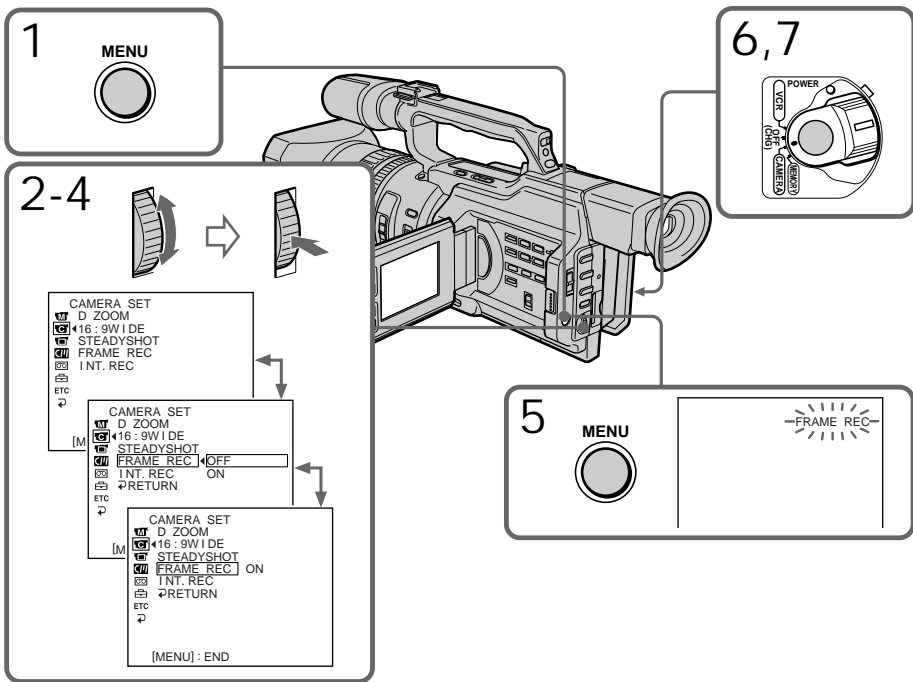

To cancel the cut recording

- Set FRAME REC to OFF in the menu settings.
- Set the POWER switch to OFF (CHG), VCR, or MEMORY.

Notes on cut recording

- The last recorded cut is longer than other cuts.
- The proper remaining tape time is not indicated if you use this function continuously.
- You cannot mark an index during cut recording.

Marking an Index

If you mark an index at the scene you want to search for, you can easily search for the scene later (p. 64).

In recording mode [a]:

Press INDEX MARK.

The "INDEX MARK" indicator appears on the LCD screen or in the viewfinder for seven seconds and the index is marked after the indicator disappears.

In standby mode [b]:

Press INDEX MARK.

The "INDEX STBY" indicator appears on the LCD screen or in the viewfinder. And when you press START/STOP to start recording, the "INDEX MARK" indicator appears on the LCD screen or in the viewfinder for seven seconds. The index is marked after the indicator disappears.

The index signal is marked on the 11th frame from the recording start point (about 0.3 sec).

You can mark an index in VCR mode (p. 88).

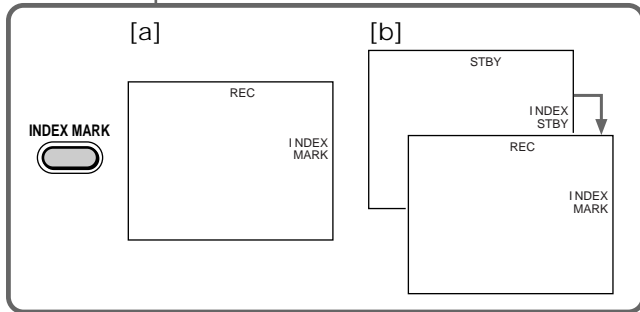
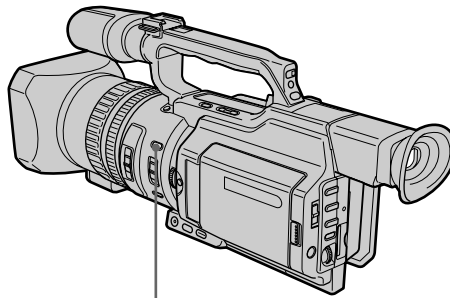

To cancel index marking

Press INDEX again in standby mode.

Note on the index

You cannot mark an index after recording.

Quickly locating a scene using the zero set memory function

Using the zero set memory function, your camcorder rewinds or advances the tape to locate the desired scene, and the searching automatically stops at the scene having a tape counter value of "0:00:00." You can do this with the Remote Commander.

- (1) In playback mode, press DISPLAY if the counter is not on the LCD screen or in the viewfinder.
- (2) Press ZERO SET MEMORY at the point you want to locate later. The tape counter shows "0:00:00" and the ZERO SET MEMORY indicator flashes.
- (3) Press ■ when you want to stop playback.
- (4) Press ◀◀ to rewind the tape to the tape counter's zero point. The tape stops automatically when the tape counter reaches approximately zero. The ZERO SET MEMORY indicator disappears and the time code appears.
- (5) Press ▶▶. Playback starts.

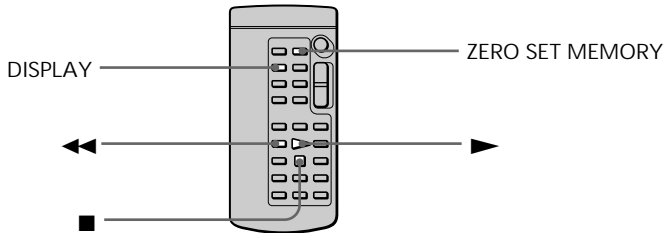

Notes

- When you press ZERO SET MEMORY again before rewinding the tape, the zero set memory function will be canceled.
- There may be a discrepancy of several seconds from the time code.

When there is a blank portion between pictures on a tape
The zero set memory function may not work.

ZERO SET MEMORY functions also in standby mode

When you insert a scene in the middle of a recorded tape, press ZERO SET MEMORY at the point you want to end the insertion. Rewind the tape to the insert start point, and start recording. Recording stops automatically at the tape counter zero point. Your camcorder returns to standby mode.

Searching for a recording by index – Index search

You can automatically search for the point where an index is marked and start playback from that point (Index search). Use a tape with cassette memory for convenience. Use the Remote Commander for this operation.

Use this function to check where indexes are marked or to edit the tape at each sequence where the index is marked.

Searching for the index point using cassette memory

You can use this function only when playing back a tape with cassette memory (p. 143).

- (1) Set the POWER switch to VCR.
- (2) Set CM SEARCH in  to ON in the menu settings (p. 107). The default setting is ON.
- (3) Press SEARCH MODE on the Remote Commander repeatedly, until the index search indicator appears.

The indicator changes as follows:

INDEX SEARCH → TITLE SEARCH → DATE SEARCH → PHOTO SEARCH
→ PHOTO SCAN → no indicator

- (4) Press  or  on the Remote Commander to select the index point for playback.

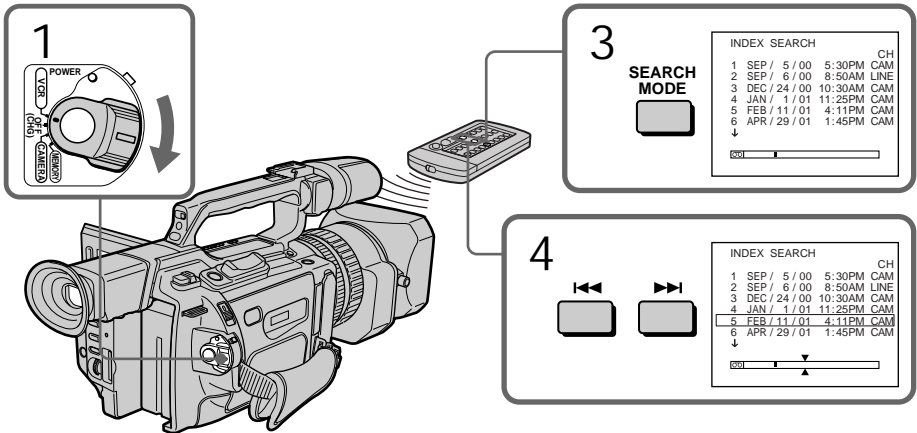

Your camcorder automatically starts playing back at the selected index point.



To stop searching
Press .

Searching for a recording by index – Index search





In the  mark

- The bar in the  mark indicates the present point on the tape.
- The  mark in the  indicates the actual point you are trying to search for.

If a tape has a blank portion between recorded portions
The index search function may not work correctly.

If you mark an index onto an external input signal
“LINE” appears in the CH column.

Searching for the index point without using cassette memory

- (1) Set the POWER switch to VCR.
- (2) Set CM SEARCH in  to OFF in the menu settings (p. 107). If using a tape without cassette memory, skip this step.
- (3) Press SEARCH MODE on the Remote Commander repeatedly, until the index search indicator appears.
The indicator changes as follows:
INDEX SEARCH → DATE SEARCH → PHOTO SEARCH → PHOTO SCAN
→ no indicator
- (4) Press  on the Remote Commander to search for the previous index point or press  on the Remote Commander to search for the next index point. Your camcorder automatically starts playback at the selected index point. Each time you press  or , your camcorder searches for the previous or next index point.



To stop searching

Press .

Searching the boundaries of recorded tape by title – Title search

CM
only

If you use a tape with cassette memory, you can search for the boundaries of recorded tape by title (Title search) (p. 143). Use the Remote Commander for this operation.

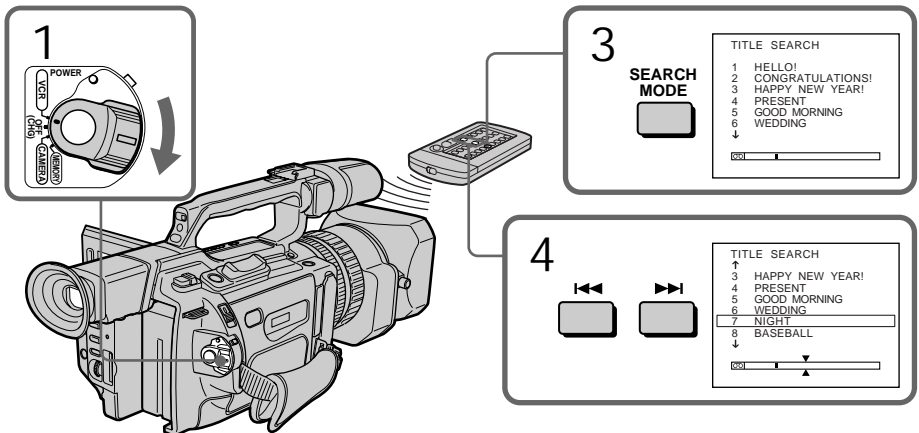

- (1) Set the POWER switch to VCR.
- (2) Set CM SEARCH in  to ON in the menu settings (p. 107). The default setting is ON.
- (3) Press SEARCH MODE on the Remote Commander repeatedly, until the title search indicator appears.
The indicator changes as follows:
INDEX SEARCH → TITLE SEARCH → DATE SEARCH → PHOTO SEARCH → PHOTO SCAN → no indicator
- (4) Press  or  on the Remote Commander to select the title for playback.
Your camcorder automatically starts playback of the scene having the title that you selected.



To stop searching
Press .

If you use a tape without cassette memory
You cannot superimpose or search for a title.

In the  mark

- The bar in the  mark indicates the present point on the tape.
- The  mark in the  indicates the actual point you are trying to search for.

If a tape has a blank portion between recorded portions
The title search function may not work correctly.

Searching a recording by date

- Date search

You can automatically search for the point where the recording date changes and start playback from that point (Date search). Use a tape with cassette memory for convenience. Use the Remote Commander for this operation.

Use this function to check where recording dates change or to edit the tape at each recording date.



Searching for the date using cassette memory

You can use this function only when playing back a tape with cassette memory (p. 143).

- (1) Set the POWER switch to VCR.
- (2) Set CM SEARCH in  to ON in the menu settings (p. 107). The default setting is ON.
- (3) Press SEARCH MODE on the Remote Commander repeatedly, until the date search indicator appears.

The indicator changes as follows:

INDEX SEARCH → TITLE SEARCH → DATE SEARCH → PHOTO SEARCH → PHOTO SCAN → no indicator

- (4) Press  or  on the Remote Commander to select the date for playback. Your camcorder automatically starts playback at the beginning of the selected date.

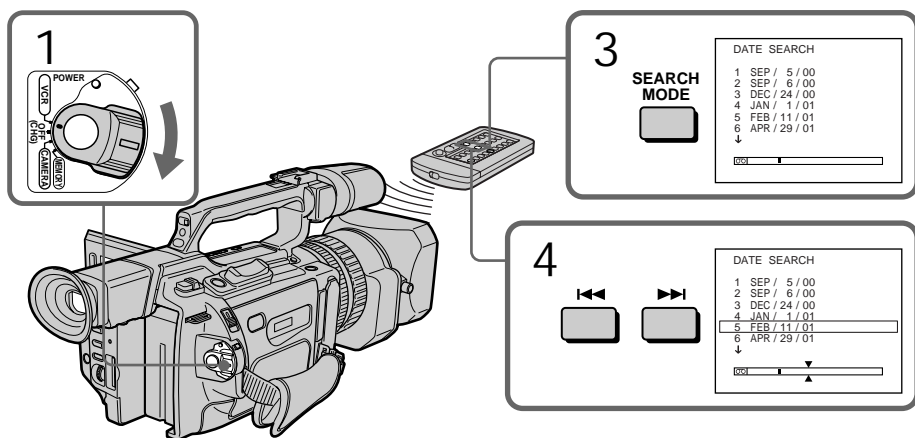



To stop searching
Press .

Searching a recording by date – Date search

Note





If one day's recording is less than two minutes, your camcorder may not accurately find the point where the recording date changes.

In the  mark

- The bar in the  mark indicates the present point on the tape.
- The X mark in the  indicates the actual point you are trying to search.

If a tape has a blank portion between recorded portions
The date search function may not work correctly.

Searching for the date without using cassette memory

- (1) Set the POWER switch to VCR.
- (2) Set CM SEARCH in  to OFF in the menu settings (p. 107). If using a tape without cassette memory, skip this step.
- (3) Press SEARCH MODE on the Remote Commander repeatedly, until the date search indicator appears.
The indicator changes as follows:
INDEX SEARCH → DATE SEARCH → PHOTO SEARCH → PHOTO SCAN
→ no indicator
- (4) Press  on the Remote Commander to search for the previous date or press  on the Remote Commander to search for the next date. Your camcorder automatically starts playback at the point where the date changes. Each time you press  or , your camcorder searches for the previous or next date.

To stop searching



Press .

Searching for a photo – Photo search/ Photo scan

You can search for a still picture you have recorded on a mini DV tape (photo search). You can also search for still pictures one after another and display each picture for five seconds automatically regardless of cassette memory (photo scan). Use the Remote Commander for these operations. Use this function to check or edit still pictures.

Searching for a photo using cassette memory

You can use this function only when playing back a tape with cassette memory (p. 143).

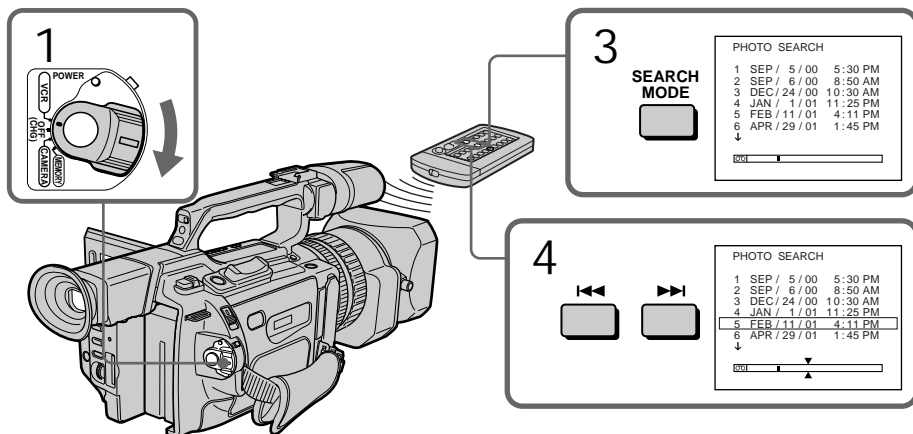

- (1) Set the POWER switch to VCR.
- (2) Set CM SEARCH in  to ON in the menu settings (p. 107). Default setting is ON.
- (3) Press SEARCH MODE on the Remote Commander repeatedly, until the photo search indicator appears.
The indicator changes as follows:
INDEX SEARCH → TITLE SEARCH → DATE SEARCH → PHOTO SEARCH → PHOTO SCAN → no indicator
- (4) Press  or  on the Remote Commander to select the date for playback. Your camcorder automatically starts playback of the photo having the date that you selected.



To stop searching





Press .

In the  mark

- The bar in the  mark indicates the present point on the tape.
- The  mark in the  indicates the actual point you are trying to search for.

If a tape has a blank portion between recorded portions
The photo search function may not work correctly.



Searching for a photo without using cassette memory

- (1) Set the POWER switch to VCR.
- (2) Set CM SEARCH in  to OFF in the menu settings (p. 107).
- (3) Press SEARCH MODE on the Remote Commander repeatedly, until the photo search indicator appears.
The indicator changes as follows:
INDEX SEARCH → DATE SEARCH → PHOTO SEARCH → PHOTO SCAN → no indicator
- (4) Press  or  on the Remote Commander to select a photo for playback.
Each time you press  or , your camcorder searches for the previous or next photo.
Your camcorder automatically starts playback of the photo.

To stop searching

Press .

Scanning photo

- (1) Set the POWER switch to VCR.
- (2) Press SEARCH MODE on the Remote Commander repeatedly, until the photo scan indicator appears.
The indicator changes as follows:
INDEX SEARCH → TITLE SEARCH → DATE SEARCH → PHOTO SEARCH → PHOTO SCAN → no indicator
- (3) Press  or  on the Remote Commander.
Each photo is played back for about five seconds automatically.

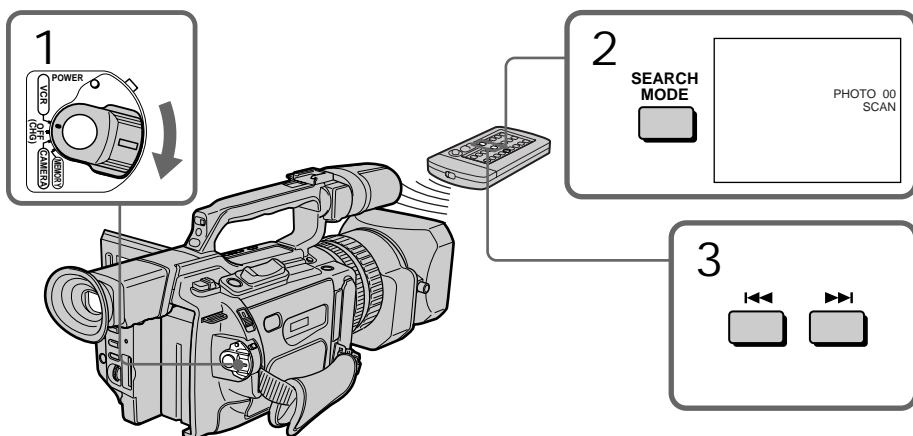

To stop scanning

Press .

Playing back a tape with picture effects

During playback, you can process a scene using the picture effect functions: NEG. ART, SEPIA, B&W and SOLARIZE.

In playback or playback pause mode, press PICTURE EFFECT and turn the SEL/PUSH EXEC dial until the desired picture effect indicator (NEG. ART, SEPIA, B&W or SOLARIZE) appears.

For details of each picture effect function, see page 39.

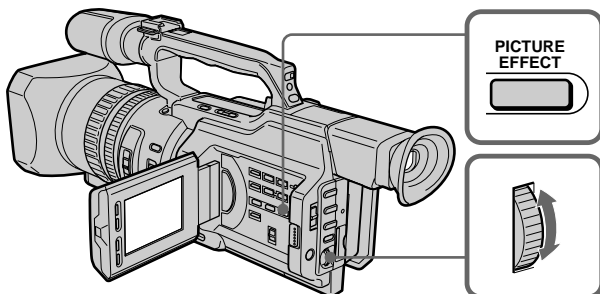

To cancel the picture effect function

Press PICTURE EFFECT so that the indicator disappears.

Notes

- You cannot process a picture using the picture effect function that is input from other equipment.
- To record pictures that you have processed using the picture effect function, record the pictures on the VCR, using your camcorder as a player.

Pictures processed by the picture effect function

Pictures processed by the picture effect function are not output through the DV IN/OUT jack.

When you set the POWER switch to OFF (CHG) or stop playing back

The picture effect function will be automatically canceled.

Playing back a tape with digital effects

During playback, you can process a scene using the digital effect functions: STILL, FLASH, LUMI, and TRAIL.

- (1) In playback or playback pause mode, press DIGITAL EFFECT and turn the SEL/PUSH EXEC dial until the desired digital effect indicator (STILL, FLASH, LUMI, or TRAIL) flashes.
- (2) Press the SEL/PUSH EXEC dial.
The digital effect indicator lights up and the bars appear. In STILL or LUMI mode, the picture is captured and is stored in memory as a still picture at the time you press the SEL/PUSH EXEC dial.
- (3) Turn the SEL/PUSH EXEC dial to adjust the effect.
For details of each digital effect function, see page 40.

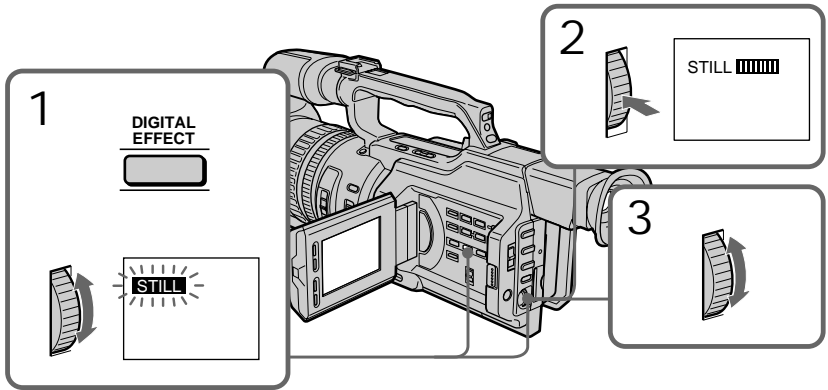

To cancel the digital effect function
Press DIGITAL EFFECT so that the indicator disappears.

Notes

- You cannot process a picture using the digital effect function that is input from other equipment.
- To record pictures that you have processed using the digital effect function, record the pictures on the VCR, using your camcorder as a player.

Pictures processed by the digital effect function

Pictures processed by the digital effect function are not output through the DV IN/OUT jack.

When you set the POWER switch to OFF (CHG) or stop playing back
The digital effect function will be automatically canceled.

Dubbing a tape

Using the A/V connecting cable

Connect your camcorder to the VCR using the A/V connecting cable supplied with your camcorder.

Before a dubbing

Set DISPLAY to LCD in the menu settings. (Default setting is LCD.)

Set the input selector on the VCR to LINE, if available.

- (1) Insert a blank tape (or a tape you want to record over) into the VCR, and insert the recorded tape into your camcorder.
- (2) Set the input selector on the VCR to LINE. For details, refer to the operating instructions of the VCR.
- (3) Set the POWER switch to VCR.
- (4) Play back the recorded tape on your camcorder.
- (5) Start recording on the VCR. For details, refer to the operating instructions of the VCR.

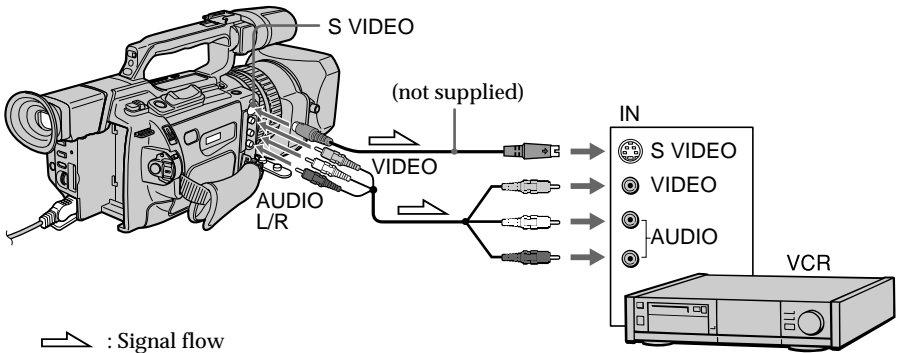

When you have finished dubbing the tape

Press **■** on both your camcorder and the VCR.

Be sure to clear the indicators from the screen

If they are displayed, press the following buttons so as not to record the indicators on the dubbed tape:

- The DISPLAY button
- The DATA CODE button
- The SEARCH MODE button on the Remote Commander

You can edit on VCRs that support the following systems

8 8 mm, **Hi8** Hi8, **D** Digital8, **VHS** VHS, **S-VHS** S-VHS, **VHS-C** VHS-C, **S-VHS-C** S-VHS-C, **B** Betamax, **ED Beta** ED Betamax, **Mini DV** mini DV or **DV** DV

If your VCR is a monaural type

Connect the yellow plug of the A/V connecting cable to the video input jack and the white plug to the audio input jack on the VCR or the TV. The red plugs are not used.

Dubbing a tape

Connect using an S video cable (not supplied) to obtain high-quality pictures. With this connection, you do not need to connect the yellow (video) plug of the A/V connecting cable. Connect the S video cable (not supplied) to the S video jacks on both your camcorder and the TV or the VCR. This connection produces higher quality DV format pictures.

If you use a LANC cable

You can edit precisely by connecting a LANC cable (not supplied) to this camcorder and other video equipment having a fine synchro-editing function, using this camcorder as a player.

Using an i.LINK cable (DV connecting cable)

Simply connect the i.LINK cable (DV connecting cable) (not supplied) to **i** DV IN/OUT and to DV IN/OUT of the DV products. With a digital-to-digital connection, video and audio signals are transmitted in digital form for high-quality editing. You cannot dub the titles, display indicators or the contents of cassette memory.

- (1) Insert a blank tape (or a tape you want to record over) into the VCR, and insert the recorded tape into your camcorder.
- (2) Set the input selector on the VCR to the DV input position if the VCR is equipped with an input selector. For details, refer to the operating instructions of the VCR.
- (3) Set the POWER switch to VCR.
- (4) Play back the recorded tape on your camcorder.
- (5) Start recording on the VCR.

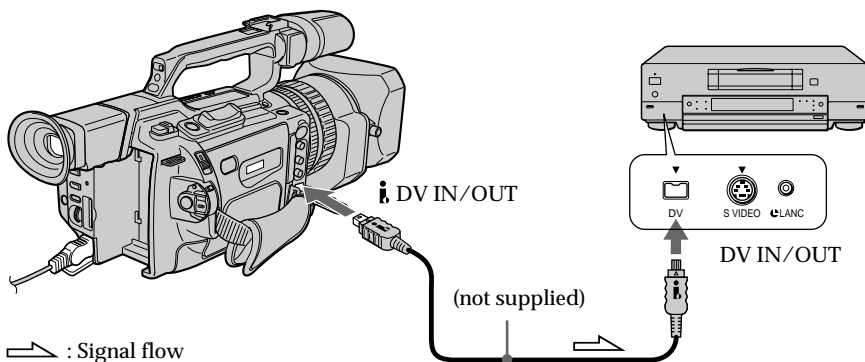

When you have finished dubbing a tape

Press **■** on both your camcorder and the VCR.

You can connect one VCR only using the i.LINK cable (DV connecting cable)

Pictures processed by the digital effect or picture effect function

Pictures processed by the digital effect or picture effect function are not output through the **i** DV IN/OUT jack.

If you record a playback pause picture with the **i** DV IN/OUT jack

The recorded picture becomes rough. And when you play back the picture using other video equipment, the picture may jitter.

Dubbing only desired scenes – Digital program editing

You can duplicate selected scenes (programs) for editing onto a tape without operating the VCR. Scenes can be selected by frame.

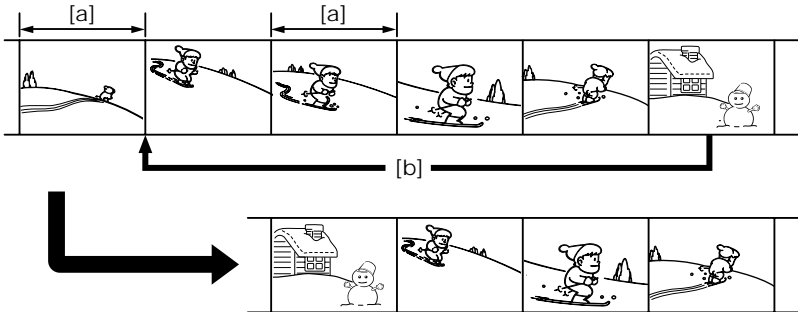

[a] Undesired frame
[b] Moves the scene

Before operating the digital program editing

Preparation 1 Connecting the VCR (p. 73, 74).

Preparation 2 Setting the VCR to operate by infrared rays emitter (p. 76)/Setting the VCR to operate with an i.LINK cable (DV connecting cable) (p. 80).

Preparation 3 Adjusting the synchronization of the VCR (p. 81).

When you dub using the same VCR again, you can skip Preparations 2 and 3.

Using the digital program editing function

Operation 1 Making programs (p. 83).

Operation 2 Performing a digital program editing (Dubbing a tape) (p. 85).

Notes

- You cannot dub the titles, display indicators, or the contents of cassette memory.
- When you connect with an i.LINK cable (DV connecting cable), you may not be able to operate the dubbing function correctly, depending on the VCR.
Set CONTROL to IR in the menu settings of your camcorder.
- You cannot send the control signal of the digital program editing through the  (LANC) jack.

If you connect using an i.LINK cable (DV connecting cable)

With digital-to-digital connection, video and audio signals are transmitted in digital form for high-quality editing.

Preparation 1: Connecting the VCR

Connect your camcorder and the VCR as shown on pages 73 and 74.

You can use an A/V connecting cable, or an i.LINK cable (DV connecting cable).

Dubbing only desired scenes – Digital program editing

Preparation 2: Setting the VCR to operate by infrared rays emitter

To edit using the VCR, send the control signal by infrared ray to the remote sensor on the VCR. When you connect using the A/V cable, this procedure is required.

- (1) Set the POWER switch to VCR on your camcorder.
- (2) Turn the power of the connected VCR on, then set the input selector to LINE.
When you connect a video camera recorder, set its POWER switch to VCR.
- (3) Press MENU to display the menu.
- (4) Turn the SEL/PUSH EXEC dial to select **ETC**, then press the dial.
- (5) Turn the SEL/PUSH EXEC dial to select EDIT SET, then press the dial.
- (6) Turn the SEL/PUSH EXEC dial to select CONTROL, then press the dial.
- (7) Turn the SEL/PUSH EXEC dial to select IR, then press the dial.

Set the IR SETUP code

- (8) Turn the SEL/PUSH EXEC dial to select IR SETUP, then press the dial.
- (9) Turn the SEL/PUSH EXEC dial to select the IR SETUP code of your VCR, then press the dial.
See “About the IR SETUP code ” on the next page.

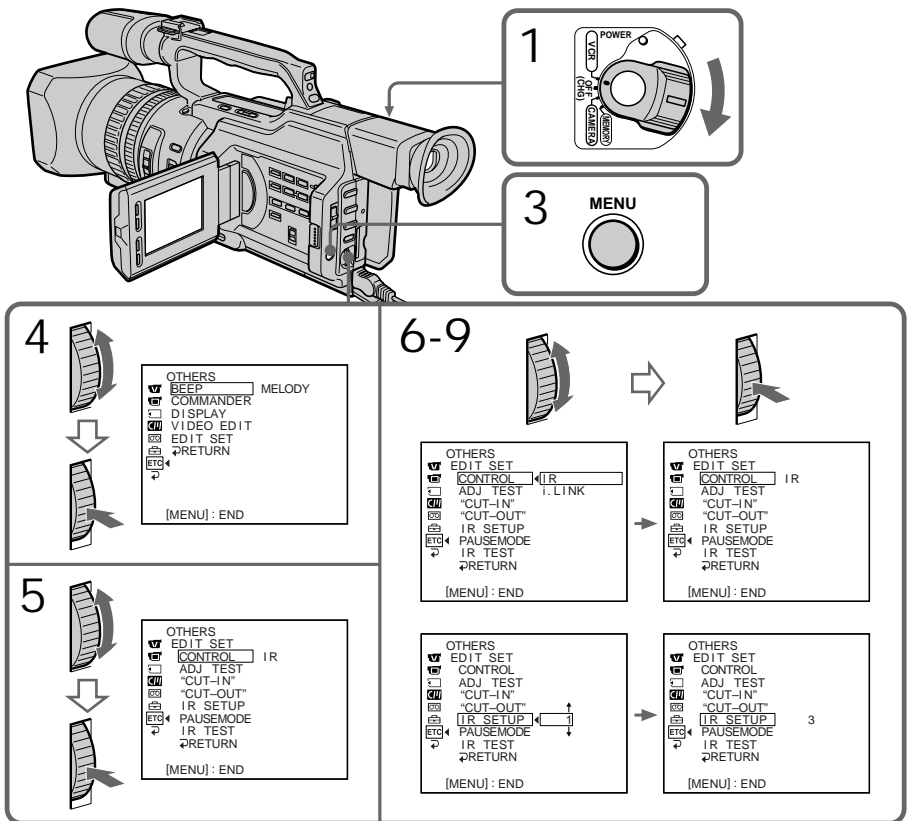

About the IR SETUP code

The IR SETUP code is stored in the memory of your camcorder. Be sure to set the correct code, depending on your VCR. Code number 1 is the default setting.

Brand	Remote control code	Brand	Remote control code
Sony	1, 2, 3, 4, 5, 6	Nokia	89, 36
Aiwa	53	Nokia Oceanic	89
Akai	62, 50, 74	Nordmende	76, 100
Alba	73	Okano	60, 62, 63
Baird	36, 30	Orion	70, 58*
Blaupunkt	83, 78	Panasonic	16, 78, 96
Bush	74	Philips	83, 84, 86
Canon	97	Phonola	83, 84
CGM	47, 83, 36	Roadstar	47
Clatronic	73	SABA	76, 21
Daewoo	26	Samsung	93, 94, 52, 22
Ferguson	76	Sanyo	36
Fisher	73	Schneider	84, 10
Funai	80	SEG	73
Goldstar	47	Seleco	47, 74
Goodmans	26, 84	Sharp	89
Grundig	83, 09	Siemens	10, 36
Hitachi	42, 56	Tandberg	26
ITT/Nikia	36	Telefunken	91, 92
Instant		Thomson	76
JVC	12, 21, 15, 11	Thorn	36, 47
Kendo	47	Toshiba	40
Loewe	16, 47, 84	Universum	92, 70, 47
Luxor	89	W. W. House	47
Mark	26*	Watson	83, 58
Matsui	47, 60, 58*		
Mitsubishi	28, 29		

* TV/VCR component

Note on remote control code

You cannot do assemble editing with some VCRs (for recording) if the remote control code does not correspond to this camcorder (for playback).

Dubbing only desired scenes – Digital program editing

Setting the buttons to cancel the recording pause on the VCR

(1) Turn the SEL/PUSH EXEC dial to select PAUSEMODE, then press the dial.

(2) Turn the SEL/PUSH EXEC dial to select the button to cancel recording pause on the VCR, then press the dial.

The correct button depends on your VCR.

Refer to the operating instructions of your VCR.

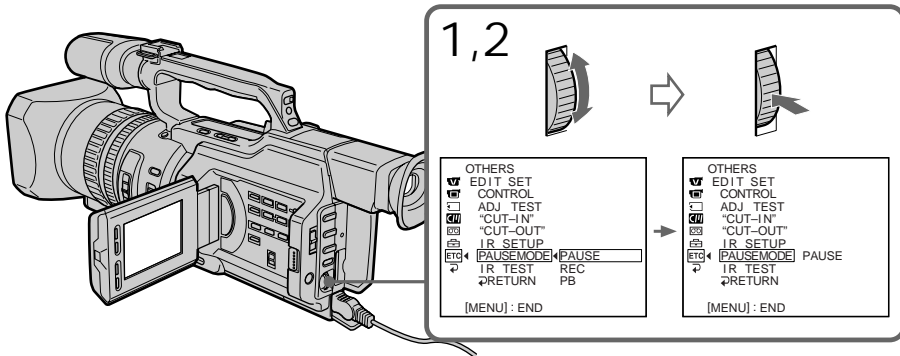

The buttons to cancel recording pause on the VCR

The buttons vary depending on your VCR. To cancel recording pause:

- Select PAUSE if the button to cancel recording pause is ■■.
- Select REC if the button to cancel recording pause is ●.
- Select PB if the button to cancel recording pause is ►.

Setting your camcorder and the VCR to face each other

Locate the infrared ray emitter of your camcorder and face it towards the remote sensor of the VCR.

Set the devices about 30 cm (about 11 7/8 in) apart, and remove any obstacles between the devices.

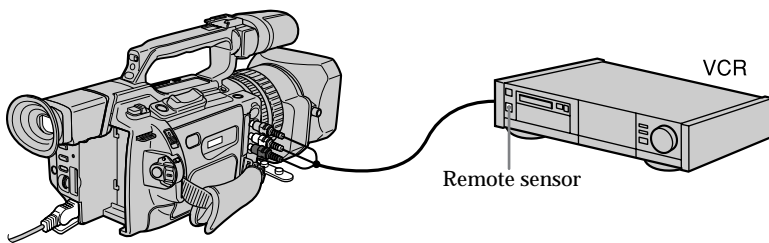

Dubbing only desired scenes – Digital program editing

Confirming the VCR operation

- (1) Insert a recordable tape into the VCR, then set it to recording pause.
- (2) Turn the SEL/PUSH EXEC dial to select IR TEST, then press the dial.
- (3) Turn the SEL/PUSH EXEC dial to select EXECUTE, then press the dial.

If the VCR starts recording, the setting is correct.

When finished, the indicator changes to COMPLETE.

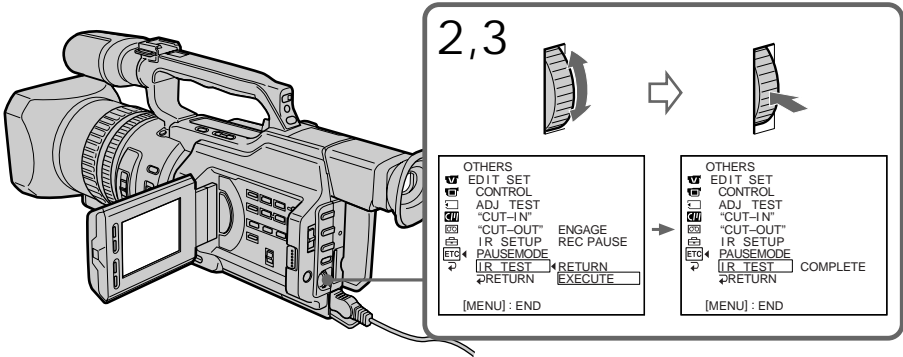

When the VCR does not operate correctly

Set the IR SETUP code, or select the button to cancel the recording pause on the VCR.

Dubbing only desired scenes – Digital program editing

Preparation 2: Setting the VCR to operate with an i.LINK cable (DV connecting cable)

When you connect using an i.LINK cable (DV connecting cable) (not supplied), follow the procedures below.

- (1) Set the POWER switch to VCR on your camcorder.
- (2) Turn the power of the connected VCR on, then set the input selector to DV input.

When you connect a video camera recorder, set its POWER switch to VCR.

- (3) Press MENU to display the menu.
- (4) Turn the SEL/PUSH EXEC dial to select **ETC**, then press the dial.
- (5) Turn the SEL/PUSH EXEC dial to select EDIT SET, then press the dial.
- (6) Turn the SEL/PUSH EXEC dial to select CONTROL, then press the dial.
- (7) Turn the SEL/PUSH EXEC dial to select i.LINK, then press the dial.

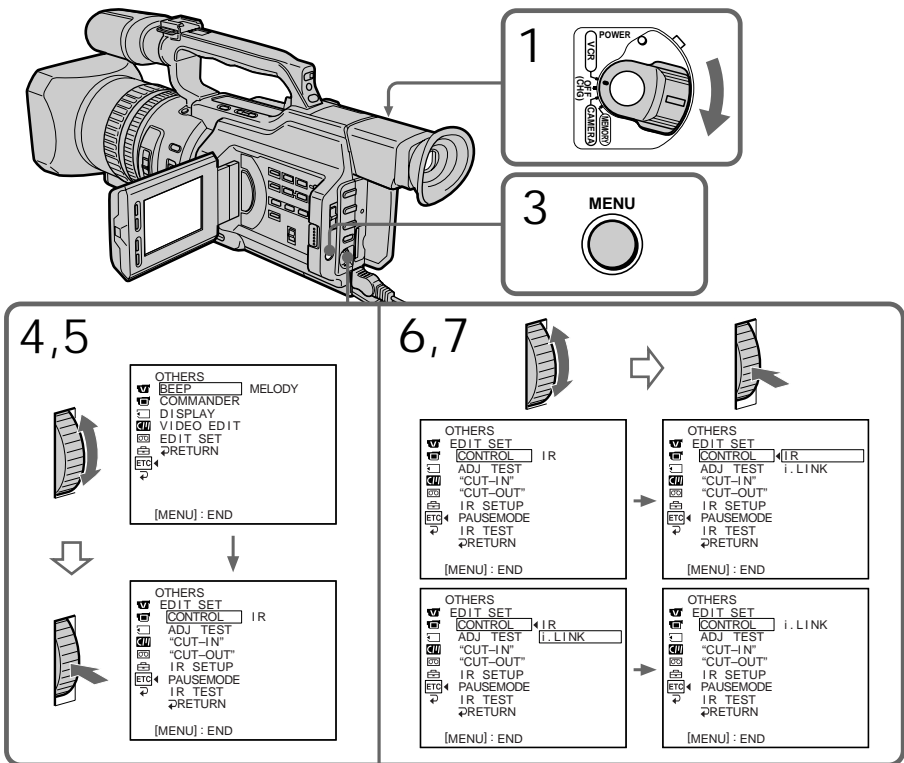

Preparation 3: Adjusting the synchronization of the VCR

You can adjust the synchronization of your camcorder and the VCR.

Remove the cassette from the camcorder beforehand. We recommend that you prepare a pen and paper for notes.

When you connect to a Sony VCR using an i.LINK cable (DV connecting cable), and have set CONTROL to i.LINK, the setup below is not necessary.

- (1) Insert a recordable tape into the VCR, then set it to recording pause.
When you connect using an i.LINK cable (DV connecting cable) and have set CONTROL to i.LINK, you do not have to turn the recording VCR to recording pause mode.
- (2) Set the POWER switch to VCR.
- (3) Press MENU to display the menu.
- (4) Turn the SEL/PUSH EXEC dial to select **ETC**, then press the dial.
- (5) Turn the SEL/PUSH EXEC dial to select EDIT SET, then press the dial.
- (6) Turn the SEL/PUSH EXEC dial to select ADJ TEST, then press the dial.
- (7) Turn the SEL/PUSH EXEC dial to select EXECUTE, then press the dial.
CUT-IN and CUT-OUT are recorded on an image for five times each to calculate the numerical values for adjusting the synchronization.
The EXECUTING indicator flashes on the LCD screen or in the viewfinder. When finished, the indicator changes to COMPLETE.
- (8) Rewind the tape in the VCR, then start slow playback.
Take a note of the opening numerical value of each CUT-IN and the closing numerical value of each CUT-OUT.
- (9) Calculate the average of all the opening numerical values of each CUT-IN, and the average of all the closing numerical values of each CUT-OUT.

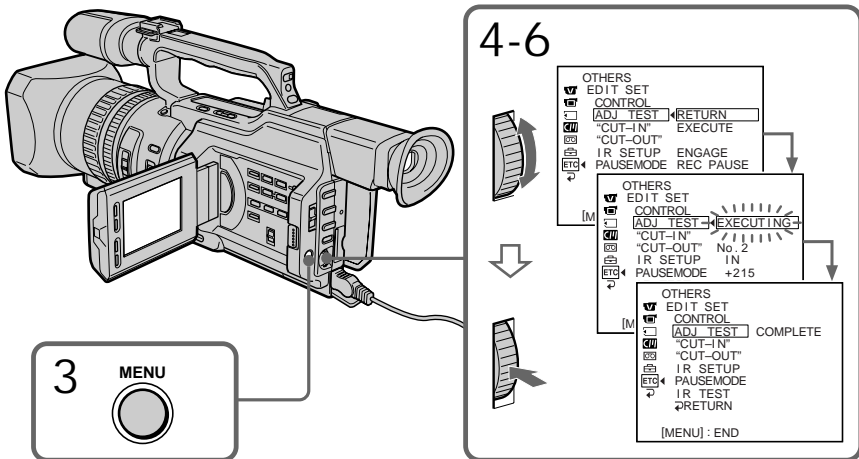

Dubbing only desired scenes – Digital program editing

- (10) Turn the SEL/PUSH EXEC dial to select “CUT-IN,” then press the dial.
- (11) Turn the SEL/PUSH EXEC dial to select the average numerical value of CUT-IN, then press the dial.
The calculated start position for recording is set.
- (12) Turn the SEL/PUSH EXEC dial to select “CUT-OUT,” then press the dial.
- (13) Turn the SEL/PUSH EXEC dial to select the average numerical value of CUT-OUT, then press the dial.
The calculated stop position for recording is set.
- (14) Turn the SEL/PUSH EXEC dial to select ↻ RETURN, then press the dial.

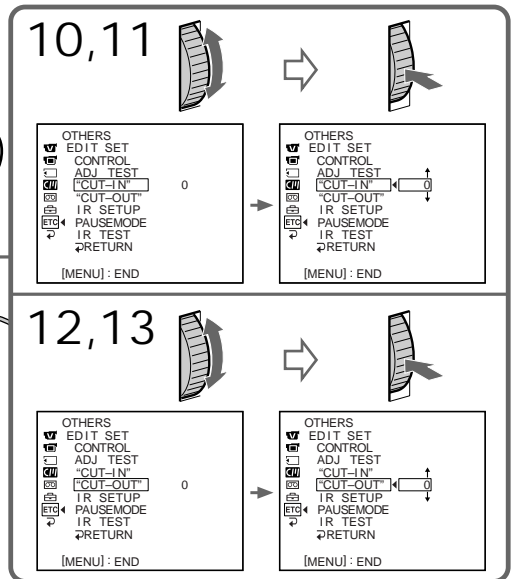
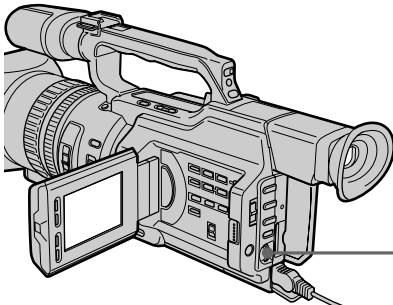

Errors in editing

If you connect your camcorder to Sony equipment with the DV jack, the range of errors is within ± 5 frames.

The range may become wider in the following conditions:

- The interval between CUT-IN and CUT-OUT is less than five seconds (p. 83).
- CUT-IN or CUT-OUT is set at the beginning of the tape.

When “ENGAGE REC PAUSE” appears on the LCD screen or in the viewfinder
Turn the recording VCR to recording pause mode.

Note

If you start recording from the very beginning of the tape, the first few seconds of the tape may not record properly. Be sure to allow about 10 seconds' lead before starting the recording.

Dubbing only desired scenes – Digital program editing

If the VCR does not operate correctly
Make sure the IR SETUP code is correct; reset if necessary.

When the operations of the VCR do not work with an i.LINK cable
Keep the i.LINK connection, and carry out Preparation 2 (p. 76) again. The audio and video signals are sent as digital signals.

Operation 1: Making Programs

- (1) Insert the tape for playback into your camcorder, and insert a tape for recording into the VCR.
- (2) Press MENU to display the menu.
- (3) Turn the SEL/PUSH EXEC dial to select **ETC**, then press the dial.
- (4) Turn the SEL/PUSH EXEC dial to select VIDEO EDIT, then press the dial.
- (5) Search for the beginning of the first scene you want to insert using the video control buttons, then pause playback (p. 29).

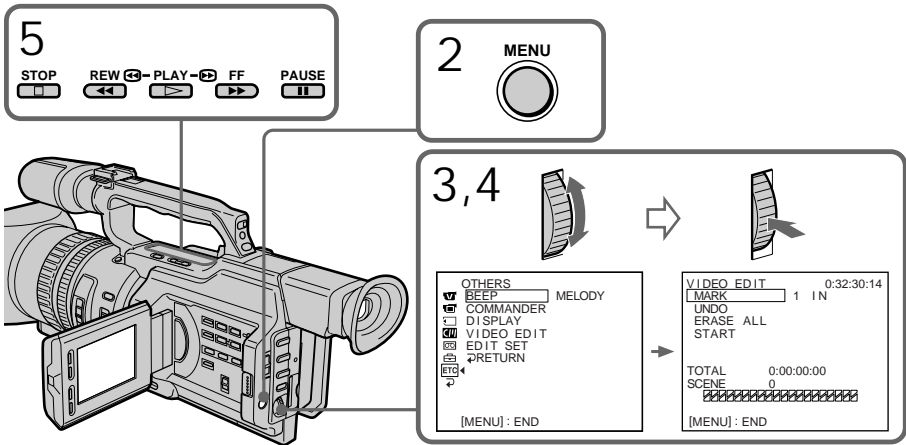

Dubbing only desired scenes – Digital program editing

- (6) Press the SEL/PUSH EXEC dial, or MARK on the Remote Commander.
The CUT-IN point of the first program is set, and the top part of the program mark changes to light blue.
- (7) Search for the end of the first scene you want to insert using the video operating buttons, then pause playback (p. 29).
- (8) Press the SEL/PUSH EXEC dial, or MARK on the Remote Commander.
The CUT-OUT point of the first program is set, then the bottom part of the program mark changes to light blue.
- (9) Repeat steps 5 to 8, then set the program.
When the program is set, the program mark changes to light blue.
You can set a maximum of 20 programs.

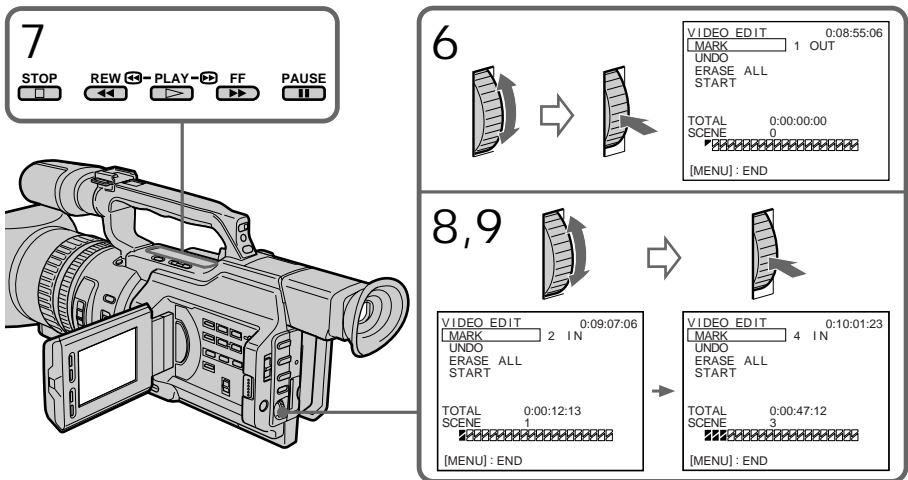

On a blank portion of the tape
You cannot set CUT-IN or CUT-OUT on a blank portion of the tape.

Note

The total time of the programs is indicated on the LCD screen or in the viewfinder, however, if the time code on the tape is not continuous, the time may not be indicated properly.

Erasing the last program

To change the end of the last program, delete the CUT-OUT mark.

To erase the whole program, delete both the CUT-IN and CUT-OUT marks.

- (1) Turn the SEL/PUSH EXEC dial to select UNDO, then press the dial. The last set program mark flashes.
- (2) Turn the SEL/PUSH EXEC dial to select EXECUTE, then press the dial and the setting is canceled.

To cancel erasing

Select RETURN in step 2, then press the SEL/PUSH EXEC dial.

Erasing all programs

- (1) Select VIDEO EDIT in the menu settings. Turn the SEL/PUSH EXEC dial to select ERASE ALL, then press the dial. All the program marks flash.
- (2) Turn the SEL/PUSH EXEC dial to select EXECUTE, then press the dial and the settings are canceled.

Dubbing only desired scenes – Digital program editing

To cancel erasing all programs
Select RETURN in step 2, then press the SEL/PUSH EXEC dial.

To cancel a program you have set
Press MENU.
The program is stored in memory until the tape is ejected.

Operation 2: Performing a digital program editing (Dubbing a tape)

Make sure your camcorder and VCR are connected, and that the VCR is set to recording pause. When you use an i.LINK cable (DV connecting cable), you do not have to set the VCR to recording pause.

When you use a video camera recorder, set its POWER switch to VCR.

- (1) Select VIDEO EDIT. Turn the SEL/PUSH EXEC dial to select START, then press the dial.
- (2) Turn the SEL/PUSH EXEC dial to select EXECUTE, then press the dial.
The camcorder automatically searches for the beginning of the first program, then starts dubbing.
The EXECUTING indicator flashes.
The SEARCH indicator appears during search, and the EDIT indicator appears during edit on the LCD screen or in the viewfinder.
The program marks light up after dubbing is complete.
When the dubbing ends, your camcorder and the VCR automatically stop.

To stop dubbing
Press ■ on this camcorder or on the Remote Commander.

To end the digital program editing function
Your camcorder stops when the dubbing is complete. Then the display returns to VIDEO EDIT in the menu settings.
Press MENU to end the digital program editing function.

When the operations of the VCR do not work with an i.LINK cable
Keep the i.LINK connection, and carry out Preparation 2 (p. 76) again.

You cannot record on the VCR when:

- The cassette is not inserted.
- The tape has run out.
- The write-protect tab is set to the protect position.
- The IR SETUP code is not correct. (When IR is selected.)
- The setup to cancel recording pause is not correct (p. 78). (When IR is selected.)

NOT READY appears on the LCD screen when:

- The program to operate the digital program edit has not been made.
- i.LINK is selected but an i.LINK cable (DV connecting cable) is not connected. (When i.LINK is selected.)
- The power of the connected VCR is not turned on.

Using with an analog video unit and a PC – Signal convert function

You can convert the analog input signal to the digital signal and output it from the DV IN/OUT jack on this camcorder. You can capture images and sound from an analog video unit connecting a PC which has the i.LINK (DV) jack to your camcorder.

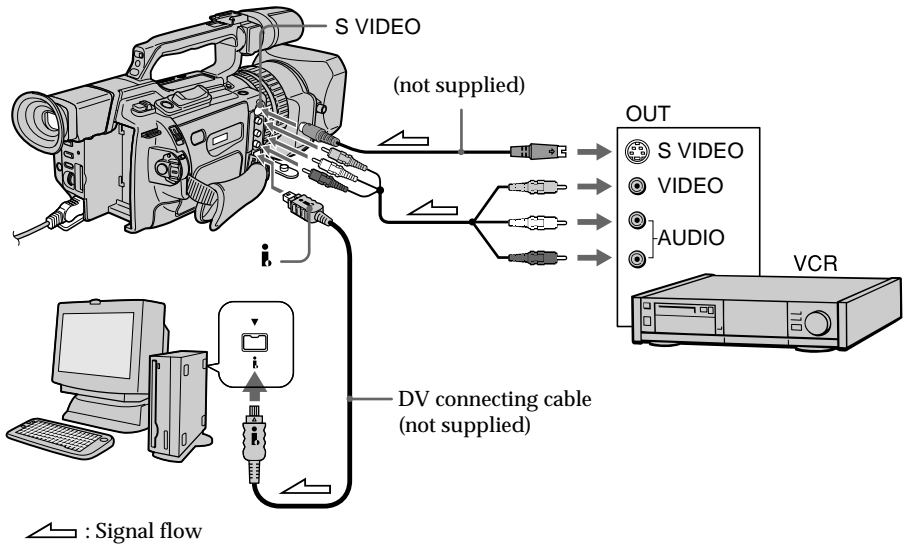

- (1) Set the POWER switch to VCR.
- (2) Press MENU to display the menu.
- (3) Turn the SEL/PUSH EXEC dial to select , then press the dial.
- (4) Turn the SEL/PUSH EXEC dial to select A/V → DV OUT, then press the dial.
- (5) Turn the SEL/PUSH EXEC dial to select ON, then press the dial.
- (6) Press MENU to erase the menu display.
- (7) Start playback on the analog video unit slightly ahead of the point from which you want to start capturing images.
- (8) Start capturing procedures on your PC. The operation procedures depend on your PC and the software which you use.
For details on how to capture images, refer to the instruction manual of your PC and your software.

After capturing images and sound
Stop capturing procedures on your PC, and stop the playback on the analog video unit.

Notes

- When you edit the captured image and sound from the analog video unit by a PC, you need to install an appropriate software which can exchange video signals between the camcorder and a PC.
- Depending on the condition of the analog video signals, the PC may not be able to output the images correctly when you convert analog video signals into digital video signals via your camcorder. Depending on the analog video unit, the image may contain noise or incorrect colors.
- The camcorder cannot output the digital signal when you input the analog signal that includes a copyright protection signal.

Recording video or TV programs

Using the A/V connecting cable

You can record a tape from another VCR or a TV program from a TV that has video/audio outputs. Use your camcorder as a recorder.

- (1) Insert a blank tape (or a tape you want to record over) into your camcorder. If you want to record a tape from the VCR, insert a recorded tape into the VCR.
- (2) Set the POWER switch to VCR on your camcorder.
- (3) Set DISPLAY in $\overline{\text{ETC}}$ to LCD in the menu settings (p. 107).
- (4) Press MENU to erase the menu display.
- (5) Press ● REC and the button on its right simultaneously on your camcorder, then immediately press ■ on your camcorder.
- (6) Press ► on the VCR to start playback if you record a tape from a VCR. Select a TV program if you record from a TV. The picture from a TV or VCR appears on the LCD screen or in the viewfinder.
- (7) Press ■ on your camcorder at the scene from which you want to start recording.

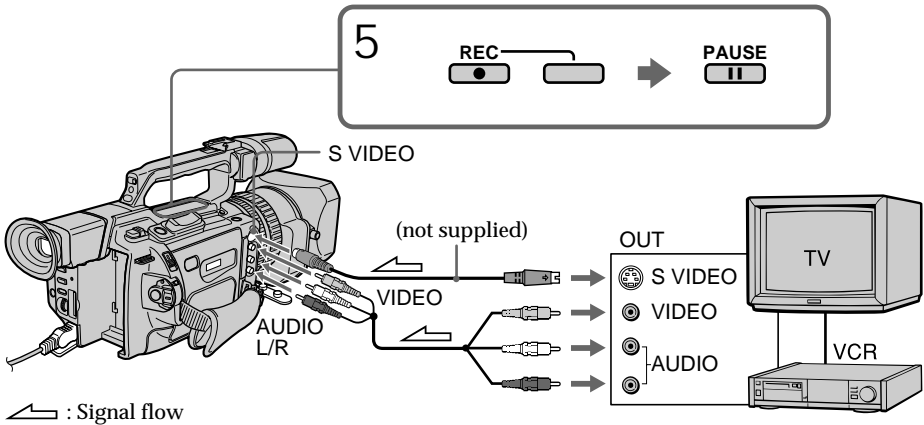

When you have finished recording

Press ■ on both your camcorder and the VCR.

Using the Remote Commander

In step 5, press ● REC and MARK simultaneously, then immediately press ■. And in step 7, press ■ at the scene from which you want to start recording.

Recording video or TV programs

If your VCR is a monaural type

Connect the yellow plug of the A/V connecting cable to the video output jack and the white plug to the audio output jack on the VCR or the TV. The red plugs are not used.

Connect using an S video cable (not supplied) to obtain high-quality pictures

With this connection, you do not need to connect the yellow (video) plug of the A/V connecting cable.

Connect an S video cable (not supplied) to the S video jacks of both your camcorder and the VCR.

This connection produces higher quality DV format pictures.

If you do various playbacks on the VCR during recording

The recorded picture may be blurred.

On the commander mode

Your camcorder works in the commander mode, VTR 2. Commander modes 1, 2 and 3 are used to distinguish your camcorder from other Sony VCRs to avoid remote control misoperation. If you use another Sony VCR in the commander mode VTR 2, we recommend changing the commander mode or covering the sensor of the VCR with black paper.

On index signal

The index is automatically marked on a tape when you start recording. If you mark the index using the INDEX MARK button during recording, "LINE" appears in the CH column on the INDEX SEARCH screen, and the index is recorded on cassette memory.

Recording video or TV programs

Using an i.LINK cable (DV connecting cable)

Simply connect the i.LINK cable (DV connecting cable) (not supplied) to DV IN/OUT and to DV IN/OUT of the DV products. With digital-to-digital connection, video and audio signals are transmitted in digital form for high-quality editing.

- (1) Insert a blank tape (or a tape you want to record over) into your camcorder, and insert the recorded tape into the VCR.
- (2) Set the POWER switch to VCR on your camcorder.
- (3) Set DISPLAY in $\overline{\text{E}}\text{T}\overline{\text{O}}$ to LCD in the menu settings (p. 107).
- (4) Press MENU to erase the menu display.
- (5) Press \bullet REC and the button on its right simultaneously on your camcorder, then immediately press II on your camcorder.
- (6) Press \blacktriangleright on the VCR to start playback. The picture to be recorded appears on the LCD screen or in the viewfinder.
- (7) Press II on your camcorder at the scene from which you want to start recording.

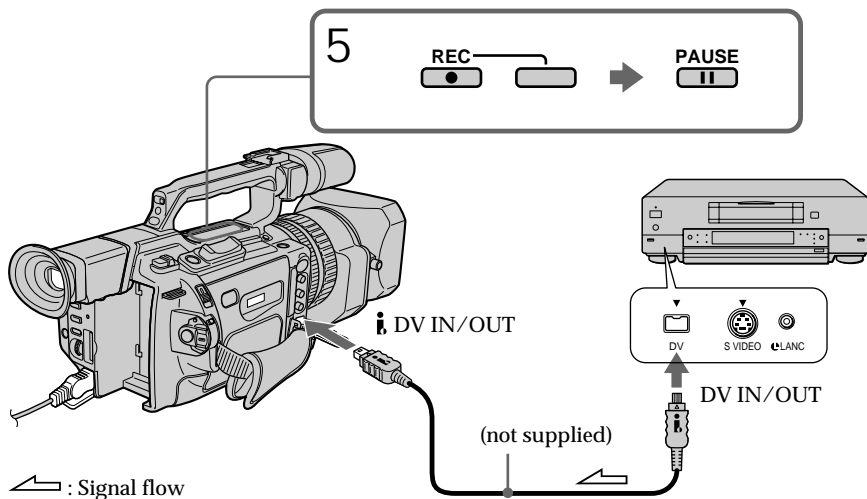

When you have finished recording

Press \blacksquare on both your camcorder and the VCR.

Using the Remote Commander

In step 5, press \bullet REC and MARK simultaneously, then immediately press II . And in step 7, press II at the scene from which you want to start recording.

Recording video or TV programs

You can connect only one VCR using the i.LINK cable (DV connecting cable)

When you dub a picture in digital form

The color of the display may be uneven. However this does not affect the dubbed picture.

If you record a still picture in playback pause mode via the  DV IN/OUT jack

The recorded picture becomes rough. And when you play back the picture using your camcorder, the picture may jitter.

Before recording

Press DISPLAY and make sure that the DV IN indicator appears on the LCD screen or in the viewfinder. The DV IN indicator may appear on both pieces of equipment.

Inserting a scene from a VCR – Insert editing

You can insert a new scene from a VCR onto your originally recorded tape by specifying the insert start and end points. Use the Remote Commander for this operation. Connections are the same as on page 73 or 86. Insert a cassette containing the desired scene into the VCR.

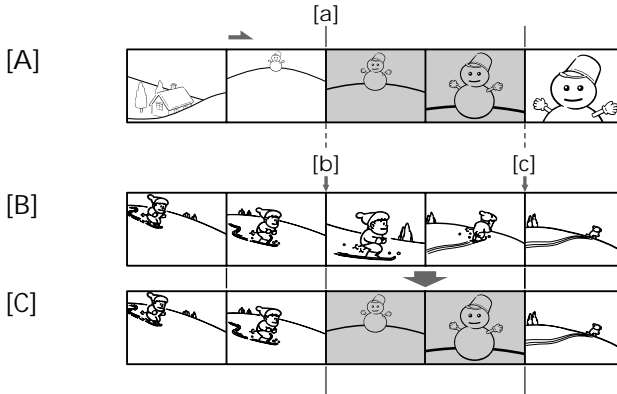

- [A]: The tape that contains the scene to be superimposed
[B]: The tape to be edited
[C]: The tape after editing

- (1) Set the POWER switch to VCR on your camcorder.
- (2) On the VCR, locate a point just before the insert start point [a], then press **II** to set the VCR to the playback pause mode.
- (3) On your camcorder, locate the insert end point [c] by pressing **◀◀** or **▶▶**. Then press **II** to set it to the playback pause mode.
- (4) Press ZERO SET MEMORY on the Remote Commander. The ZERO SET MEMORY indicator flashes and the end point of the insert is stored in memory. The tape counter shows "0:00:00." If the tape counter does not appear, press DISPLAY.
- (5) On your camcorder, locate the insert start point [b] by pressing **◀◀**, then press **● REC** and the button on its right simultaneously, then immediately press **II** on your camcorder.
- (6) First press **II** on the VCR, and after a few seconds press **II** on your camcorder to start inserting the new scene. Inserting automatically stops near the zero point on the tape counter. Your camcorder automatically returns to the recording pause mode.

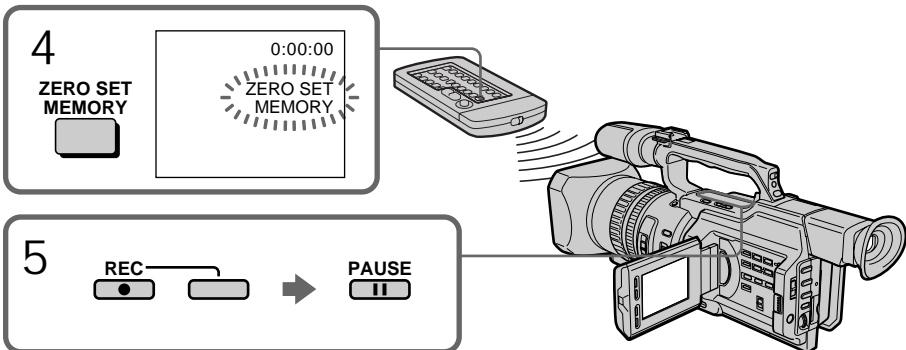

Inserting a scene from a VCR – Insert editing

To change the insert end point

Press ZERO SET MEMORY on the Remote Commander again after step 5 to erase the ZERO SET MEMORY indicator and begin from step 3.

Using the Remote Commander

In step 5, press ●REC and MARK simultaneously, then immediately press ■■. And in step 6, press ■■ at the scene from which you want to start recording.

Note

The picture and sound recorded on the portion between the insert start and end points will be erased when you insert the new scene.

If you insert scenes on the tape recorded with an other camcorder (including an other DCR-VX2000)

The picture and sound may be distorted. We recommend that you insert scenes on a tape recorded with your camcorder.

When the inserted picture is played back

The picture and sound may be distorted at the end of the inserted portion. This is not a malfunction.

The picture and sound at the start point and the end point may be distorted in the LP mode.

To insert a scene without setting the insert end point

Skip steps 3 and 4. Press ■ when you want to stop inserting.

Audio dubbing

You can record an audio sound to add to the original sound on a tape by connecting audio equipment or a microphone. If you connect audio equipment, you can add sound to your recorded tape by specifying the starting and ending points. The original sound will not be erased. You can also use the Remote Commander for this operation.

Connecting the microphone with the MIC jack

MIC (PLUG IN POWER)

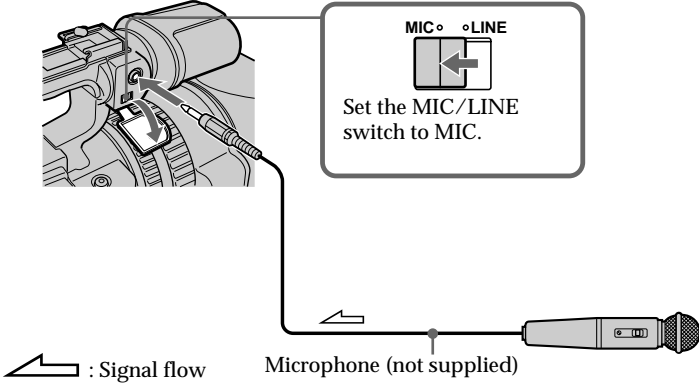

You can check the picture on TV by connecting with the video jack. You cannot monitor the additional sound by the speaker. Use the headphone jack.

Connecting the audio equipment with the MIC jack

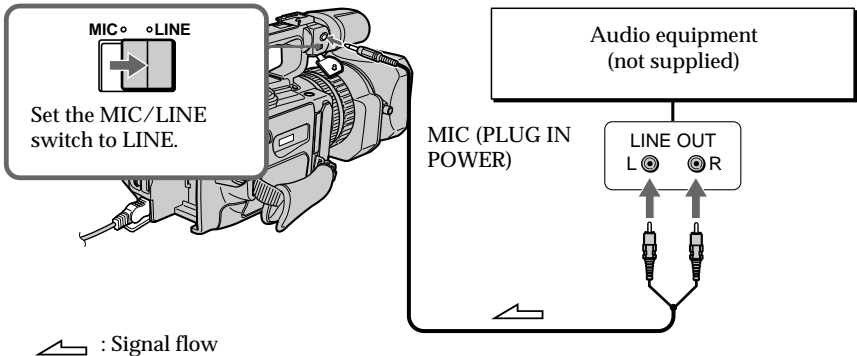

Audio dubbing

Connecting the microphone with the intelligent accessory shoe

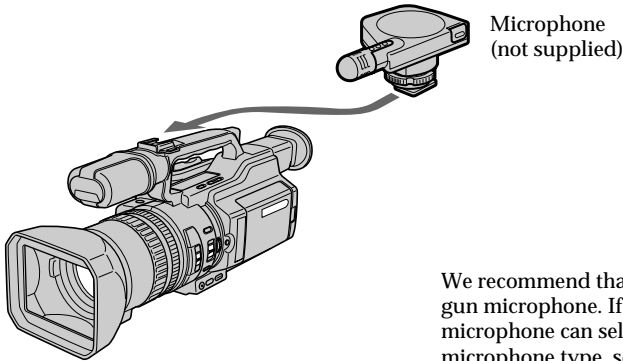

Dubbing with the AUDIO L/R jacks

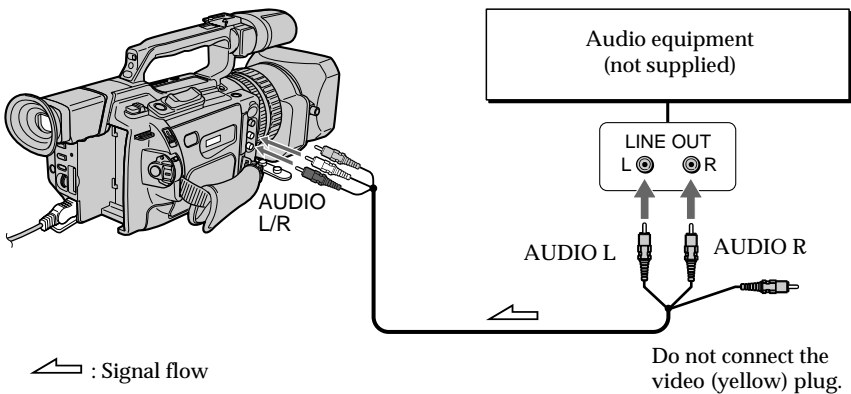

Dubbing with the supplied microphone

No connection is necessary.

Notes

- When dubbing with the built-in microphone or an external one, you can check the recorded picture on the LCD screen, in the viewfinder, or on the screen of equipment connected with the VIDEO jack, and you can check the recorded sound by using headphones.
- When dubbing with the AUDIO L/R jacks, you can check the recorded picture on the LCD screen or in the viewfinder, and you can check the recorded sound by using a headphones.
- You can check both the original sound and new sound that will be dubbed, with headphones.
- You can adjust the balance of the new sound and original sound using AUDIO MIX in the menu settings. You can monitor the sound using headphones during audio dubbing.

Adding an audio sound on a recorded tape

- (1) Insert the recorded tape into your camcorder.
- (2) Set the POWER switch to VCR on your camcorder.
- (3) Locate the recording start point by pressing ►. Then press || at the point where you want to start recording to set your camcorder to the playback pause mode.
- (4) Press ● AUDIO DUB. The green ● || indicator appears on the LCD screen or in the viewfinder.
- (5) Press || and start playing back the audio you want to record at the same time. The new sound is recorded in stereo 2 (ST2) during playback.
- (6) Press ■ at the point where you want to stop recording.

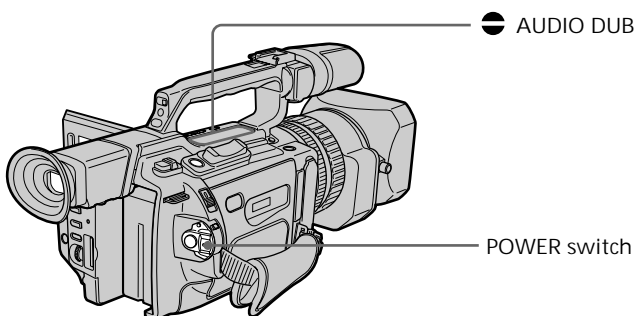

Monitoring the new recorded sound

To play back the sound

Adjust the balance between the original sound (ST1) and the new sound (ST2) by selecting AUDIO MIX in the menu settings (p. 107).

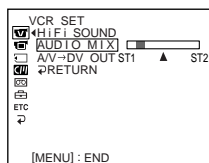

If you wait five minutes after you disconnect the power source or remove the battery pack, the setting of AUDIO MIX returns to the original sound (ST1) only. The default setting is for original sound only.

Audio dubbing

Notes

- New sound cannot be recorded on a tape already recorded in the 16-bit mode (p. 111).
- New sound cannot be recorded on a tape already recorded in the LP mode.
- You cannot add audio with the  DV IN/OUT jack.

If you make all the connections

The audio input to be recorded will take precedence over others in the following order.

- MIC (PLUG IN POWER) jack
- Intelligent accessory shoe
- AUDIO L/R jacks
- Built-in microphone

If an i.LINK cable (DV connecting cable) (not supplied) is connected to your camcorder

You cannot add sound to a recorded tape.

If you set the write-protect tab of the tape to lock

You cannot record on the tape. Slide the write-protect tab to release the write protection.

We recommend that you add new sound on a tape recorded with your camcorder

If you add new sound on a tape recorded with another camcorder (including an other DCR-VX2000), the sound quality may deteriorate.

To add new sound more precisely

Press ZERO SET MEMORY on the Remote Commander at the point where you want to stop recording later in playback mode. Then, follow the procedure from step 3.

Recording automatically stops at the point where ZERO SET MEMORY was pressed.

On blank portions

You cannot add an audio.

You can adjust the recording level manually using the recording adjustment display in the following cases:

- Dubbing with an optional external microphone or audio equipment through the MIC jack
- Dubbing with an optional external microphone installed into the intelligent accessory shoe.
- Dubbing with the internal microphone

Superimposing a title

CM
only

If you use a tape with cassette memory, you can superimpose the title while recording or after recording. When you play back the tape, the title is displayed for five seconds from the point where you superimposed it.

You can select one of eight preset titles and two custom titles (p. 101).



You can also select the color, size and position of titles.

- (1) Press TITLE to display the title menu in standby, recording, playback, or playback pause mode.
- (2) Turn the SEL/PUSH EXEC dial to select , then press the dial.
- (3) Turn the SEL/PUSH EXEC dial to select the desired title, then press the dial. The title flashes.
- (4) Change the color, or position, if necessary.
 - ① Turn the SEL/PUSH EXEC dial to select the COLOR, SIZE, or POSITION, then press the dial. The item appears.
 - ② Turn the SEL/PUSH EXEC dial to select the desired item, then press the dial.
 - ③ Repeat steps 1 and 2 until the title is laid out as desired.

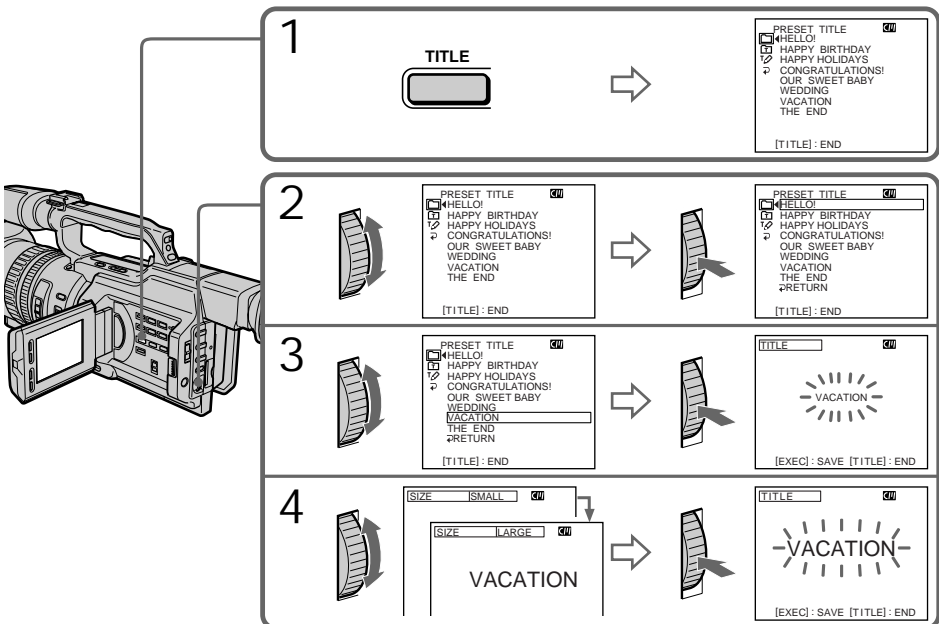

Superimposing a title

(5) Press the SEL/PUSH EXEC dial again to complete the setting.

In playback, playback pause, or recording mode:

The "TITLE SAVE" indicator appears on the screen for five seconds and the title is set.

In standby mode:

The "TITLE" indicator appears. When you press START/STOP to start recording, "TITLE SAVE" appears on the screen for five seconds and the title is set.

If you set the write-protect tab to lock

You cannot superimpose or erase the title. Slide the write-protect tab to release the write protection.

To use a custom title

If you want to use the custom title, select  in step 2.

If the tape has a blank portion

You cannot superimpose a title on that portion.

If the tape has a blank portion in the middle of the recorded parts

The title may not be displayed correctly.

The titles superimposed with your camcorder

- They are displayed only on the DV ^{Mini} DV format video equipment with the index titler function.
- The point you superimposed the title may be detected as an index signal when searching a recording with other video equipment.

To not display titles

Set TITLE DSPL to OFF in the menu settings (p. 107).

Superimposing a title

Title setting

- The title color changes as follows:
WHITE ↔ YELLOW ↔ VIOLET ↔ RED ↔ CYAN ↔ GREEN ↔ BLUE
- The title size changes as follows:
SMALL ↔ LARGE
You cannot input more than 12 characters in LARGE size.
- If you select the title size "SMALL," you have nine choices for the title position.
If you select the title size "LARGE," you have eight choices for the title position.

If the "~~CH~~ FULL" mark appears

The cassette memory is full. If you erase the title, index data, date data, photo data, or cassette label in the cassette, you can then superimpose a title.

Superimposing a title

Erasing a title

- (1) Set the POWER switch to VCR or CAMERA.
- (2) Press MENU to display the menu.
- (3) Turn the SEL/PUSH EXEC dial to select , then press the dial. The title erase display appears.
- (4) Turn the SEL/PUSH EXEC dial to select TITLEERASE, then press the dial. The title erase display appears.
- (5) Turn the SEL/PUSH EXEC dial to select the title you want to erase, then press the dial. The “ERASE OK ?” indicator appears.
- (6) Make sure the title is the one you want to erase, and turn the SEL/PUSH EXEC dial to select OK, then press the dial. “OK” changes to “EXECUTE.”
- (7) Press the SEL/PUSH EXEC dial. “ERASING” flashes for about two seconds and “COMPLETE” appears after erasing the title.

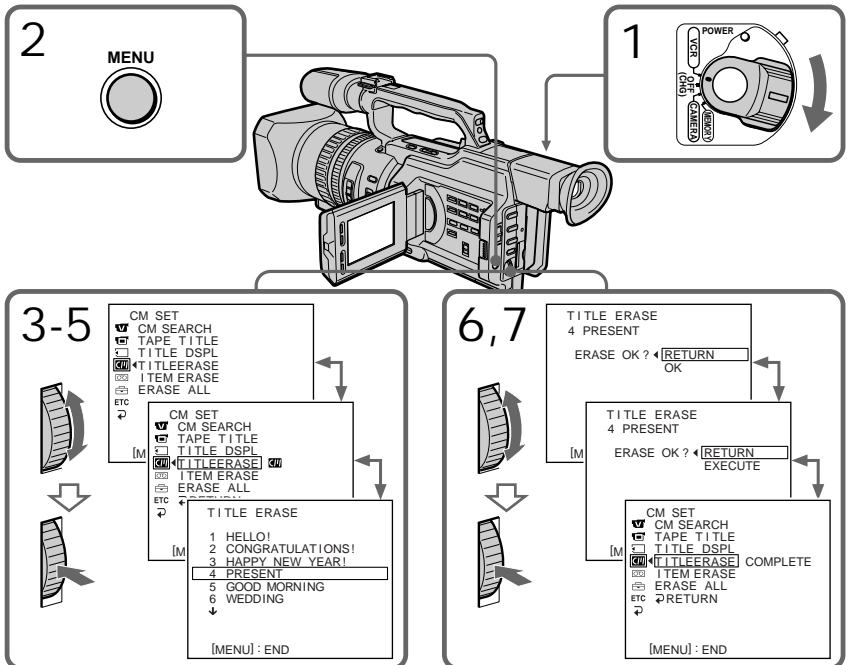

To cancel erasing

Select RETURN in step 6 or 7, then press the SEL/PUSH EXEC dial.

To erase all the titles

See “Erasing the cassette memory data” on page 105.

Making your own titles

CM
only

You can make up to two titles and store them in cassette memory. Each title can have up to 20 characters.

- (1) Press TITLE in the standby, playback, or playback pause mode.
- (2) Turn the SEL/PUSH EXEC dial to select \emptyset , then press the dial.
- (3) Turn the SEL/PUSH EXEC dial to select CUSTOM1 SET or CUSTOM2 SET, then press the dial.
- (4) Turn the SEL/PUSH EXEC dial to select the column of the desired character, then press the dial.
- (5) Turn the SEL/PUSH EXEC dial to select the desired character, then press the dial.
- (6) Repeat steps 4 and 5 until you have selected all characters and completed the title.
- (7) To finish making your own titles, turn the SEL/PUSH EXEC dial to select [SET], then press the dial. The title is stored in memory.
- (8) Press TITLE to erase the title menu display.

Editing

1

TITLE

PRESET TITLE CM

- HELLO!
- HAPPY BIRTHDAY
- HAPPY HOLIDAYS
- CONGRATULATIONS!
- OUR SWEET BABY
- WEDDING
- VACATION
- THE END

[TITLE]: END

2

TITLE SET CM

- CUSTOM1 SET
- CUSTOM2 SET
- RETURN

[TITLE]: END

3

TITLE SET CM

- CUSTOM1 SET
- CUSTOM2 SET
- RETURN

[TITLE]: END

TITLE SET CM

[ABCDE] 12345
 FGHIJ 67890
 KLMNO . / -
 PQRST [+]
 UVWXY [SET]
 Z & ? !

[TITLE]: END

4-6

1

TITLE SET CM

ABCDE 12345
 FGHIJ 67890
 KLMNO . / -
 PQRST [+]
 UVWXY [SET]
 Z & ? !

[TITLE]: END

2

TITLE SET CM

ABCDE 12345
 FGHIJ 67890
 KLMNO . / -
 PQRST [+]
 UVWXY [SET]
 Z & ? !

[TITLE]: END

3

TITLE SET CM

ABCDE 12345
 FGHIJ 67890
 KLMNO . / -
 PQRST [+]
 UVWXY [SET]
 Z & ? !

[TITLE]: END

4

TITLE SET CM

ABCDE 12345
 S

[TITLE]: END

Making your own titles

To change a title you have stored

In step 3, select CUSTOM1 SET or CUSTOM2 SET, depending on which title you want to change, then press the SEL/PUSH EXEC dial. Turn the SEL/PUSH EXEC dial to select [←], then press the dial to delete the title. The last character is erased. Enter a new title as desired.

If you take five minutes or longer to enter characters in standby mode while a cassette is in your camcorder, the power automatically goes off

The characters you have entered remain stored in memory. Set the POWER switch to OFF (CHG) once and then follow the procedure from step 7 again.

We recommend setting the operation in playback or playback pause mode or removing the cassette so that your camcorder does not automatically turn off while you are entering title characters.

To erase a character

Turn the SEL/PUSH EXEC dial to select [←], then press the dial. The last character is erased.

To enter a space

Select [Z& ? !], then select the blank part.

Labeling a cassette

CM only

If you use a tape with cassette memory, you can label a cassette. The label can consist of up to 10 characters and is stored in cassette memory. When you insert the labeled cassette and set the POWER switch to VCR, CAMERA, or MEMORY, the label is displayed for about five seconds.

- (1) Insert the cassette you want to label.
- (2) Set the POWER switch to VCR, CAMERA, or MEMORY.
- (3) Press MENU to display the menu.
- (4) Turn the SEL/PUSH EXEC dial to select **[CM]**, then press the dial.
- (5) Turn the SEL/PUSH EXEC dial to select TAPE TITLE, then press the dial. The tape title display appears.
- (6) Turn the SEL/PUSH EXEC dial to select the column of the desired character, then press the dial.
- (7) Turn the SEL/PUSH EXEC dial to select the desired character, then press the dial.
- (8) Repeat steps 6 and 7 until you finish the label.
- (9) Turn the SEL/PUSH EXEC dial to select [SET], then press the dial.
The label is stored in memory.

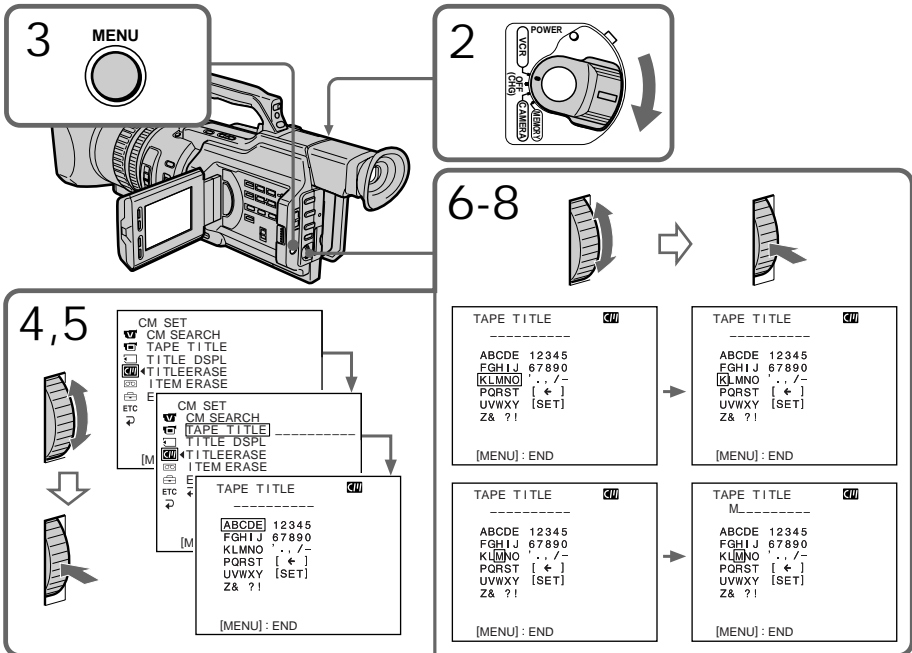

Labeling a cassette

To change the label you have made

Insert the cassette to change the label, and operate in the same way as you do to make a new label.

If you set the write-protect tab of the tape to lock

You cannot label the tape. Slide the write-protect tab to release the write protection.

If you have superimposed titles in the cassette

When the label is displayed, up to four titles also appear.

When the "----" indicator has fewer than 10 spaces

The cassette memory is full.

The "----" indicates the number of characters you can select for the label.

To erase a character

Turn the SEL/PUSH EXEC dial to select [←], then press the dial. The last character is erased.

To enter a space

Select [Z& ? !], then select the blank part.

Erasing the cassette memory data

You can erase data stored in cassette memory, each item's data can be erased separately.
You can also erase all items' data once.

Erasing each item's data separately

- (1) Set the POWER switch to VCR or CAMERA.
- (2) Press MENU to display the menu display.
- (3) Turn the SEL/PUSH EXEC dial to select **[CM]**, then press the dial.
- (4) Turn the SEL/PUSH EXEC dial to select ITEM ERASE, then press the dial.
- (5) Turn the SEL/PUSH EXEC dial to select the item that you want to erase its data, then press the dial.

Item	Meaning
INDEX ALL	Erases all the index data.
TITLE ALL	Erases all the title data.
DATE ALL	Erases all the date data.
PHOTO ALL	Erases all the photo data.

- (6) Turn the SEL/PUSH EXEC dial to select OK, then press the dial. "OK" changes to "EXECUTE."
- (7) Press the SEL/PUSH EXEC dial.
"ERASING" flashes for about two seconds and "COMPLETE" appears after erasing the selected item's data.

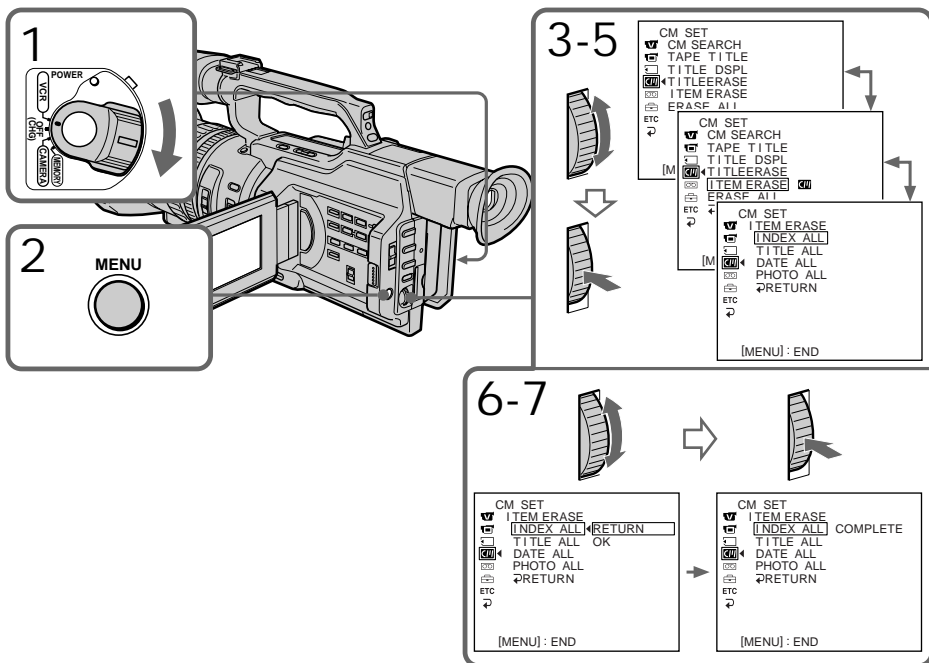

To cancel erasing
Select RETURN in step 6 or 7, then press the SEL/PUSH EXEC dial.

Erasing the cassette memory data

Erasing all the data in cassette memory

- (1) Set the POWER switch to VCR or CAMERA.
- (2) Press MENU to display the menu display.
- (3) Turn the SEL/PUSH EXEC dial to select , then press the dial.
- (4) Turn the SEL/PUSH EXEC dial to select ERASE ALL, then press the dial.
- (5) Turn the SEL/PUSH EXEC dial to select OK, then press the dial. "OK" changes to "EXECUTE."
- (6) Press the SEL/PUSH EXEC dial.
"ERASING" flashes for about two seconds and "COMPLETE" appears after erasing all the data.

To cancel erasing

Select RETURN in step 5 or 6, then press the SEL/PUSH EXEC dial.

Changing the menu settings

To change the mode settings in the menu settings, select the menu items with the SEL/PUSH EXEC dial. The default settings can be partially changed. First, select the icon, then the menu item and then the mode.

- (1) In standby, or when the POWER switch is set to VCR or MEMORY, press MENU.
- (2) Turn the SEL/PUSH EXEC dial to select the desired icon, then press the dial to set it.
- (3) Turn the SEL/PUSH EXEC dial to select the desired item, then press the dial to set it.
- (4) Turn the SEL/PUSH EXEC dial to select the desired mode, then press the dial to set it.
- (5) If you want to change other items, select RETURN and press the dial, then repeat steps 2 to 4.

For details, see “Selecting the mode setting of each item” (p. 108).

1

MENU

CAMERA

MANUAL SET
 [WORLD TIME] AUTO SHTR
 [PROG.] PROG. SCAN
 [RECALL] [RECALL]
 [EFFECT] [EFFECT]
 [ETC.] [ETC.]
 [RETURN] [RETURN]

[MENU] : END

VCR

VCR SET
 [WORLD TIME] HI/FI SOUND
 [RECALL] AUDIO MIX
 [EFFECT] AV-DV OUT
 [ETC.] [ETC.]
 [RETURN] [RETURN]

[MENU] : END

MEMORY

MANUAL SET
 [WORLD TIME] AUTO SHTR
 [RECALL] [RECALL]
 [EFFECT] [EFFECT]
 [ETC.] [ETC.]
 [RETURN] [RETURN]

[MENU] : END

2

MANUAL SET
 [WORLD TIME] AUTO SHTR
 [PROG.] PROG. SCAN
 [RECALL] [RECALL]
 [EFFECT] [EFFECT]
 [ETC.] [ETC.]
 [RETURN] [RETURN]

OTHERS

[WORLD TIME] WORLD TIME
 [RECALL] BEEP
 [EFFECT] COMMANDER
 [ETC.] DISPLAY
 [RETURN] REC LAMP
 [RETURN] COLOR BAR
 [RETURN] [RETURN]

OTHERS

[WORLD TIME] WORLD TIME 0 HR
 [RECALL] BEEP
 [EFFECT] COMMANDER ON
 [ETC.] DISPLAY
 [RETURN] REC LAMP
 [RETURN] COLOR BAR
 [RETURN] [RETURN]

3

OTHERS

[WORLD TIME] WORLD TIME 0 HR
 [RECALL] BEEP
 [EFFECT] COMMANDER ON
 [ETC.] DISPLAY
 [RETURN] REC LAMP
 [RETURN] COLOR BAR
 [RETURN] [RETURN]

OTHERS

[WORLD TIME] WORLD TIME
 [RECALL] BEEP
 [EFFECT] COMMANDER ON
 [ETC.] DISPLAY OFF
 [RETURN] REC LAMP
 [RETURN] COLOR BAR
 [RETURN] [RETURN]

4

OTHERS

[WORLD TIME] WORLD TIME
 [RECALL] BEEP
 [EFFECT] COMMANDER ON
 [ETC.] DISPLAY OFF
 [RETURN] REC LAMP
 [RETURN] COLOR BAR
 [RETURN] [RETURN]

OTHERS

[WORLD TIME] WORLD TIME
 [RECALL] BEEP
 [EFFECT] COMMANDER OFF
 [ETC.] DISPLAY
 [RETURN] REC LAMP
 [RETURN] COLOR BAR
 [RETURN] [RETURN]

Changing the menu settings



To make the menu display disappear
Press MENU.

Menu items are displayed as the following icons:

-  MANUAL SET
-  CAMERA SET
-  VCR SET
-  LCD/VF SET
-  MEMORY SET
-  CM SET
-  TAPE SET
-  SETUP MENU
-  OTHERS

Selecting the mode setting of each item ● is the default setting.

Menu items differ depending on the position of the POWER switch.
The LCD screen or viewfinder screen shows only the items you can operate at the moment.

Icon/item	Mode	Meaning	POWER switch
 AUTO SHTR	● ON	To automatically adjust the electronic shutter speed.	CAMERA MEMORY
	OFF	To fix the electronic shutter speed.	
PROG. SCAN	● OFF	Records still/moving pictures in the interlace format.	CAMERA
	ON	Records still/moving pictures in progressive mode.	
 D ZOOM	● OFF	To deactivate the digital zoom. Up to 12× zoom is carried out.	CAMERA
	24×	To activate the digital zoom. More than 12× zoom is performed digitally. This value goes up to 24× (p. 21).	
	48×	To activate the digital zoom. More than 12× zoom is performed digitally. This value goes up to 48× (p. 21).	
16:9WIDE	● OFF	To not record a 16:9 wide picture.	CAMERA
	ON	To record a 16:9 wide picture (p. 36).	
STEADYSHOT	● ON	To compensate for camera-shake.	CAMERA MEMORY
	OFF	To cancel the SteadyShot function. Natural pictures are produced when shooting a stationary object with a tripod.	





Notes on the SteadyShot function

- The SteadyShot function will not correct excessive camera-shake.
- Attachment of a conversion lens (not supplied) may influence the SteadyShot function.

If you cancel the SteadyShot function

The SteadyShot OFF indicator  appears. Your camcorder prevents excessive compensation for camera-shake.

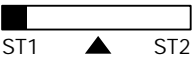
Changing the menu settings

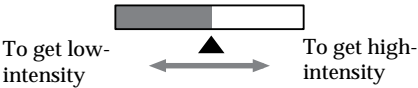
Icon/item	Mode	Meaning	POWER switch
 FRAME REC	● OFF	Does not make a cut recording.	CAMERA
	ON	Makes a cut recording (p. 61).	
INT. REC	ON	Makes an interval recording (p. 59).	CAMERA
	● OFF	Does not make an interval recording.	
	SET	Sets the interval time and recording time.	
 HiFi SOUND	● STEREO	To play back a stereo tape or dual sound track tape with main and sub sound (p. 144).	VCR
	1	To play back a stereo tape with the left sound or a dual sound tape with main sound.	
	2	To play back a stereo tape with the right sound or a dual sound track tape with sub sound.	
AUDIO MIX	—	To adjust the balance between the stereo 1 and stereo 2 (p. 95).	VCR
			
A/V→DV OUT	● OFF	To output analog images in digital format using your camcorder.	VCR
	ON	To output digital images in analog format using your camcorder.	
 LCD B. L.	● BRT NORMAL	To set the brightness on the LCD screen to normal.	VCR CAMERA
	BRIGHT	To brighten the LCD screen.	MEMORY
LCD COLOR	—	To adjust the color on the LCD screen with the SEL/PUSH EXEC dial.	VCR CAMERA MEMORY
			
VF B.L.	● BRT NORMAL	To set the brightness on the viewfinder screen to normal.	VCR CAMERA
	BRIGHT	To brighten the viewfinder screen.	MEMORY
GUIDEFAME	● OFF	Does not display the guide frame.	CAMERA
	ON	Displays the guide frame (p. 35).	MEMORY

Notes on LCD B.L. and VF B.L.

- When you select “BRIGHT,” battery life is reduced a little during recording.
- When you use power sources other than the battery pack, “BRIGHT” is automatically selected.

Changing the menu settings

Icon/item	Mode	Meaning	POWER switch
CONTINUOUS	● OFF	Not to record continuously.	MEMORY
	ON	To record four images continuously (p. 121).	
	MULTI SCRN	To record nine images continuously (p. 121).	
QUALITY	● SUPER FINE (SFN)	To record still images in the super fine image quality mode, using a “Memory Stick” (p. 118).	VCR MEMORY
	FINE (FINE)	To record still images in the fine image quality mode, using a “Memory Stick” (p. 118).	
	STANDARD (STD)	To record still images in the standard image quality mode, using a “Memory Stick” (p. 118).	
PRINT MARK	● OFF	To erase print marks on still images.	VCR
	ON	To write a print mark on the recorded still images you want to print out later.	MEMORY
PROTECT	● OFF	To release protection from still images.	VCR
	ON	To protect selected still images against accidental erasure (p. 138).	MEMORY
SLIDE SHOW		To play back all the images as a slide show (p. 137).	MEMORY
DELETE ALL		To delete all unprotected images (p. 140).	MEMORY
FORMAT	● RETURN	To cancel formatting.	MEMORY
	OK	To format an inserted “Memory Stick.” 1. Select FORMAT with the SEL/PUSH EXEC dial, then press the dial. 2. Turn the SEL/PUSH EXEC dial to select OK, then press the dial. 3. After “EXECUTE” appears, press the SEL/PUSH EXEC dial. “FORMATTING” appears during formatting. “COMPLETE” appears when formatting is finished.	
PHOTO SAVE		To duplicate images on a mini DV tape onto a “Memory Stick” (p. 130).	VCR

Formatting erases all information on the “Memory Stick”

Check the contents of the “Memory Stick” before formatting:

- Formatting erases sample images on the “Memory Stick.”
- Formatting erases the protected image data on the “Memory Stick.”



Notes on formatting

- Supplied or optional “Memory Stick”s have been formatted at the factory. Formatting with this camcorder is not required.
- While the display shows “FORMATTING,” do not turn the POWER switch, press any button, or eject a “Memory Stick.”
- You cannot format a “Memory Stick” if the write-protect tab on the “Memory Stick” is set to LOCK.
- Format again if the message “ ” appears.

If formatting fails

The “ FORMAT ERROR” message appears.

Changing the menu settings

Icon/item	Mode	Meaning	POWER switch
 CM SEARCH	● ON	To search using cassette memory (p. 64, 66, 67, 69).	VCR
	OFF	To search without using cassette memory.	
TAPE TITLE		To label a cassette (p. 103).	VCR CAMERA
TITLE DSPL	● ON	To display the title you have superimposed.	VCR
	OFF	Not to display the title.	
TITLEERASE	—	To erase the title you have superimposed (p. 100).	VCR CAMERA
ITEM ERASE	—	To erase each item's data in cassette memory (p. 105).	VCR CAMERA
ERASE ALL	—	To erase all the data in cassette memory (p. 106).	VCR CAMERA
 REC MODE	● SP	To record in the SP (Standard Play) mode.	VCR CAMERA
	LP	To increase the recording time to 1.5 times the SP mode.	
AUDIO MODE	● 12BIT	To record in 12-bit mode (two stereo sounds).	VCR CAMERA
	16BIT	To record in 16-bit mode (one stereo sound with high quality).	



Notes on the LP mode

- When you record a tape in the LP mode on your camcorder, we recommend playing back the tape on your camcorder. When you play back the tape on other camcorders or VCRs, noise may occur in pictures or sound.
- When you record in the LP mode, we recommend using a Sony Excellence/Master mini DV cassette so that you can get the most out of your camcorder.
- You cannot make audio dubbing on a tape recorded in the LP mode. Use the SP mode for the tape to be audio-dubbed.
- When you record in the SP and LP modes on one tape or you record some scenes in the LP mode, the playback picture may be distorted or the time code may not be written properly between scenes.

Notes on AUDIO MODE

- You cannot dub an audio sound on a tape recorded in the 16-bit mode.
- When playing back a tape recorded in the 16-bit mode, you cannot adjust the balance in AUDIO MIX.

Changing the menu settings

Icon/item	Mode	Meaning	POWER switch
 REMAIN	● AUTO	To display the remaining tape indication: <ul style="list-style-type: none"> • for about eight seconds after your camcorder is turned on and calculates the remaining amount of tape • for about eight seconds after a cassette is inserted and your camcorder calculates the remaining amount of tape • for about eight seconds after ► is pressed in VCR mode • for about eight seconds after DISPLAY is pressed to display the screen indicators • for the period of tape rewinding, forwarding or picture search in the VCR mode 	VCR CAMERA
	ON	To always display the remaining tape indicator.	
DATA CODE	● DATE/CAM	To display date, time and various settings during playback.	VCR
	DATE	To display date and time during playback.	
MIC LEVEL	● AUTO	Adjusts audio recording level automatically.	VCR
	MANUAL	Adjusts audio recording level manually (p. 51).	CAMERA
 CLOCK SET	—	To reset the date or time (p. 114).	CAMERA MEMORY
LTR SIZE	● NORMAL	To display selected menu items in normal size.	VCR CAMERA
	2×	To display selected menu items at twice the normal size.	MEMORY
DEMO MODE	● ON	To make the demonstration appear.	CAMERA
	OFF	To cancel the demonstration mode.	
 WORLD TIME		To set the clock to the local time. Turn the SEL/PUSH EXEC dial to set a time difference. The clock changes by the time difference you set here. If you set the time difference to 0, the clock returns to the originally set time.	CAMERA MEMORY

Notes on DEMO MODE

- You cannot select DEMO MODE when a cassette is inserted in your camcorder.
- DEMO MODE is set to STBY (Standby) at the factory and the demonstration starts about 10 minutes after you have set the POWER switch to CAMERA without a cassette inserted.

To cancel the demonstration, insert a cassette, set the POWER switch to other than CAMERA, or set DEMO MODE to OFF.

Changing the menu settings

Icon/item	Mode	Meaning	POWER switch
[ETC] BEEP	● MELODY	To chime a melody in normal operations, and beep a warning sound for five seconds.	VCR CAMERA MEMORY
	NORMAL	To beep in the following situations: turning on the power, pressing the start/stop button, and when a warning message appears.	
	OFF	To cancel the melody, beep, and shutter click sound.	
COMMANDER	● ON	To activate the Remote Commander supplied with your camcorder.	VCR CAMERA MEMORY
	OFF	To deactivate the Remote Commander to avoid remote control misoperation caused by an other VCR's remote control.	
DISPLAY	● LCD	To show the display on the LCD screen and viewfinder screen.	VCR CAMERA MEMORY
	V-OUT/LCD	To show the display on a TV screen, LCD screen and viewfinder screen.	
REC LAMP	● ON	To light up the camera recording lamps at the front and rear of your camcorder.	CAMERA MEMORY
	OFF	To turn the camera recording lamps off.	
COLOR BAR	● OFF	Does not display the color bar.	CAMERA
	ON	Displays the color bar.	
VIDEO EDIT		To make programs and perform video editing (p. 83).	VCR
EDIT SET		To adjust and set the synchronization of your camcorder and a VCR for dubbing in video program editing mode (p. 76).	VCR

Note

If you press DISPLAY with DISPLAY set to V-OUT/LCD in the menu settings, the picture from a TV or VCR will not appear on the LCD screen even when your camcorder is connected to outputs on the TV or VCR (except using an i.LINK cable (DV connecting cable)).

When recording a close subject

When REC LAMP is set to ON, the red camera recording lamps on the front and rear of the camcorder may reflect on the subject if it is close. In this case, we recommend you set REC LAMP to OFF.

After more than five minutes after removing the power source
The "PROG. SCAN," "HiFi SOUND," "AUDIO MIX," "MIC LEVEL," and
"COMMANDER" items are returned to their default settings.

The other menu items are held in memory even when the power source is removed.

Resetting the date and time

The default clock setting is set to Tokyo time for the models sold in Japan, and New York time for other models.

If you do not use your camcorder for about four months, the date and time settings may be released (bars may appear) because the vanadium-lithium battery installed in your camcorder will have been discharged (p. 158).

First, set the year, then the month, the day, the hour and then the minute.

- (1) Press MENU to display the menu in the standby mode.
- (2) Turn the SEL/PUSH EXEC dial to select , then press the dial.
- (3) Turn the SEL/PUSH EXEC dial to select CLOCK SET, then press the dial.
- (4) Turn the SEL/PUSH EXEC dial to adjust to the desired year, then press the dial.
- (5) Set the month, day and hour by turning the SEL/PUSH EXEC dial and pressing the dial.
- (6) Set the minute by turning the SEL/PUSH EXEC dial and pressing the dial by the time signal. The clock starts to move.
- (7) Press MENU to erase the menu display.

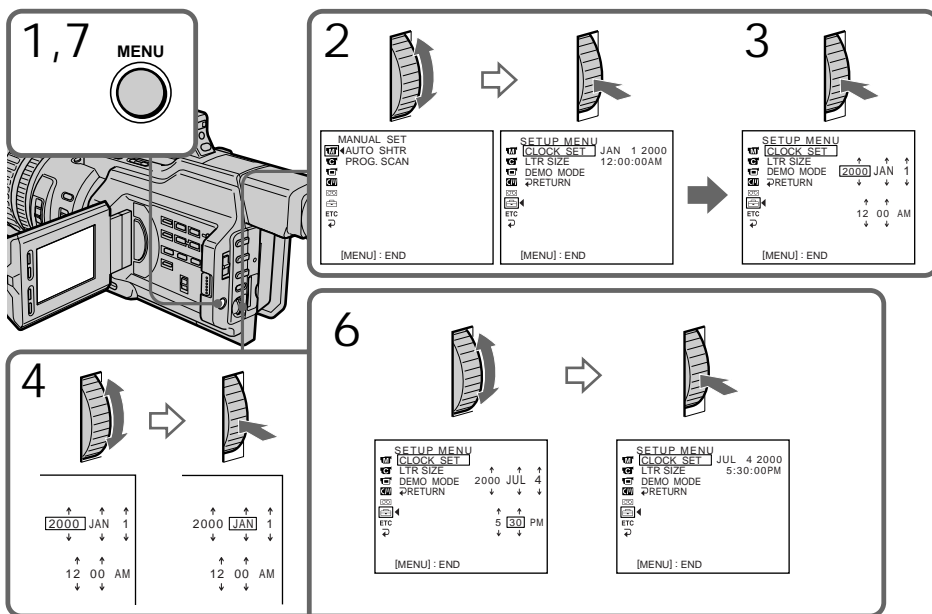

The year changes as follows:

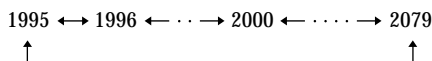

If you do not set the date and time

“--:--:--” (time) and “---:---” (date) are recorded on the data code of the tape and the “Memory Stick.”

Note on the time indicator

The internal clock of your camcorder operates on a 12-hour cycle.

- 12:00 AM stands for midnight.
- 12:00 PM stands for noon.

Using a “Memory Stick” – introduction

You can record and play back still images on the “Memory Stick” supplied with your camcorder. You can easily play back, record or delete still images. You can exchange image data with other equipment such as a personal computer etc., using the Memory Stick Reader/Writer supplied with your camcorder or a PC card adaptor for Memory Stick (not supplied).

On file format (JPEG)

Your camcorder compresses image data in JPEG format (extension .jpg).

Typical image data file name

100-0001: As displayed on the LCD screen or in the viewfinder of the camcorder.

Dsc00001.jpg: As displayed on your PC screen.

Before using a “Memory Stick”

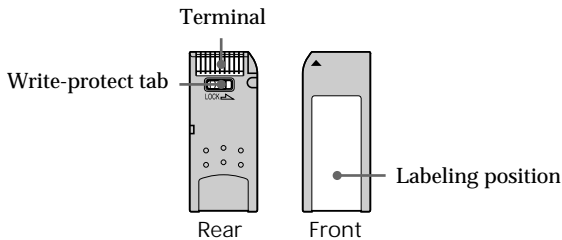

- You cannot record or erase still images when the write-protect tab on the “Memory Stick” is set to LOCK.
- We recommend backing up important data.
- Image data may be damaged in the following cases:
 - If you remove the “Memory Stick,” turn the power off, or detach the battery for replacement when the access lamp is flashing.
 - If you use a “Memory Stick” near static electricity or magnetic fields.
- Prevent metallic objects or your finger from coming into contact with the metal parts of the connecting section.
- Stick its label on the labeling position.
- Do not bend, drop or apply strong shock to a “Memory Stick.”
- Do not disassemble or modify a “Memory Stick.”
- Do not let the “Memory Stick” get wet.
- Do not use or keep a “Memory Stick” in locations that are:
 - Extremely hot such as in a car parked in the sun or under the scorching sun.
 - Under direct sunlight.
 - Very humid or subject to corrosive gases.
- When you carry or store a “Memory Stick,” put it in its case.

A “Memory Stick” formatted by a computer

A “Memory Stick” formatted by the Windows OS or Macintosh computers does not have a guaranteed compatibility with this camcorder.

Notes on image data compatibility

- Image data files recorded on a “Memory Stick” by your camcorder conform to the Design Rules for Camera File Systems universal standard (DCF98 standard) established by the JEIDA (Japan Electronic Industry Development Association). You cannot play back on your camcorder still images recorded on other equipment (DCR-TRV890E/TRV900/TRV900E or DSC-D700/D770) that does not conform to this universal standard. (These models are not sold in some areas.)
- If you cannot use a “Memory Stick” that is used with other equipment, format it with this camcorder (p. 110). However, formatting erases all information on the “Memory Stick.”

“Memory Stick” and  are trademarks of Sony Corporation.

-
- Windows is a registered trademark licensed to Microsoft Corporation, registered in the U.S.A. and other countries.
 - Macintosh and Mac OS are trademarks of Apple Computer, Inc.
 - All other product names mentioned herein may be the trademarks or registered trademarks of their respective companies.

Furthermore, “™” and “®” are not mentioned in each case in this manual.

Using a "Memory Stick" – introduction

Inserting a "Memory Stick"

Insert the "Memory Stick" with the Sony logo pointing toward the LCD panel and the ◀ mark pointing inward.

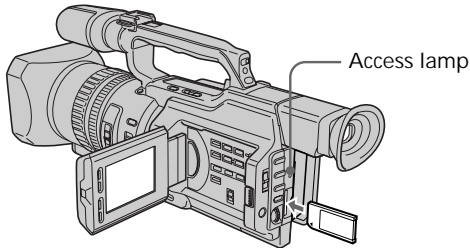

To eject a "Memory Stick"

Push the "Memory Stick" inward, then release your finger. The "Memory Stick" comes out a little.

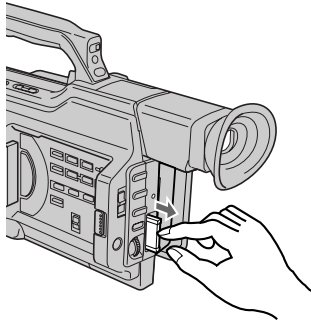

Note

The "Memory Stick" may pop out depending on the way you push it.

When the access lamp is lit or flashing

Never shake or strike your camcorder. Do not turn the power off, eject a "Memory Stick" or remove the battery pack. Otherwise, image data breakdown may occur.

If the "MEMORY STICK ERROR" indicator appears

The "Memory Stick" is broken or the file format is not proper. Eject the "Memory Stick," check it, and insert it again. If the same indicator appears, use another "Memory Stick."

Using a "Memory Stick" – introduction

Selecting the image quality mode

You can select the image quality mode in still picture recording. The default setting is SUPER FINE.

- (1) Set the POWER switch to VCR or MEMORY. Make sure that the LOCK switch is set to the right (unlock) position.
- (2) Press MENU to display the menu.
- (3) Turn the SEL/PUSH EXEC dial to select , then press the dial.
- (4) Turn the SEL/PUSH EXEC dial to select QUALITY, then press the dial.
- (5) Turn the SEL/PUSH EXEC dial to select the desired image quality, then press the dial.

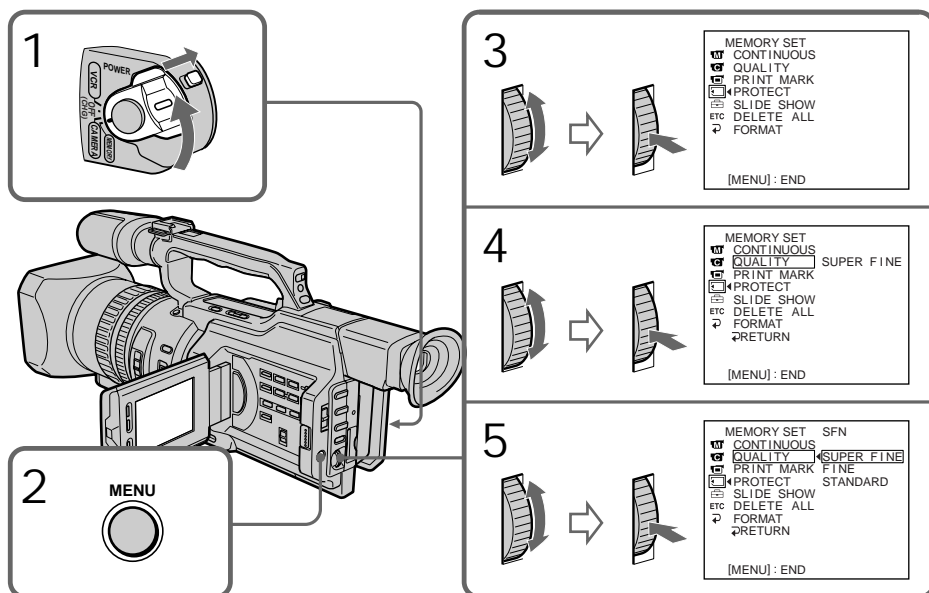

Image quality settings

Setting (Display)	Meaning
SUPER FINE (SFN)	This is the highest image quality in this camcorder. The number of still images you can record is fewer than FINE. The image is compressed to about 1/3.
FINE (FINE)	Use this mode when you want to record high quality images. The image is compressed to about 1/6.
STANDARD (STD)	This is the standard image quality. The image is compressed to about 1/10.

Note

In some cases, changing the image quality mode may not affect the image quality, depending on the types of images you are shooting.

Using a “Memory Stick” – introduction

Differences in image quality mode

Recorded images are compressed in JPEG format before being stored in memory. The memory capacity allotted to each image varies depending on the image quality mode selected. Details are shown in the table below.

Image quality mode	Memory capacity
SUPER FINE	Approx. 190 KB
FINE	Approx. 100 KB
STANDARD	Approx. 60 KB

Note on the image quality mode indicator

This is only displayed during recording.

The approximate number of images you can record on a “Memory Stick”

The approximate number of images you can record on a “Memory Stick” that is formatted using this camcorder varies depending on which image quality mode you select and the complexity of the subject.

	Image quality mode		
	SUPER FINE (SFN)	FINE (FINE)	STANDARD (STD)
4 MB type (supplied)	20 images	40 images	60 images
8 MB type (not supplied)	40 images	81 images	122 images
16 MB type (not supplied)	82 images	164 images	246 images
32 MB type (not supplied)	164 images	329 images	494 images
64 MB type (not supplied)	329 images	659 images	988 images

Recording still images on a “Memory Stick” – Memory Photo recording

You can record still images on a “Memory Stick.”

Before operation

Insert a “Memory Stick” into your camcorder.

- (1) Set the POWER switch to MEMORY. Make sure that the LOCK switch is set to the right (unlock) position.
- (2) Keep pressing PHOTO lightly until the desired still picture appears. The green ● mark stops flashing, then lights up. The brightness of the picture and focus are re-adjusted, being targeted for the middle of the picture and are fixed. Recording does not start yet.
- (3) Press PHOTO deeply. The shutter clicks and the image is frozen. The image displayed on the screen will be recorded on the “Memory Stick.” Recording is complete when the bar scroll indicator disappears.

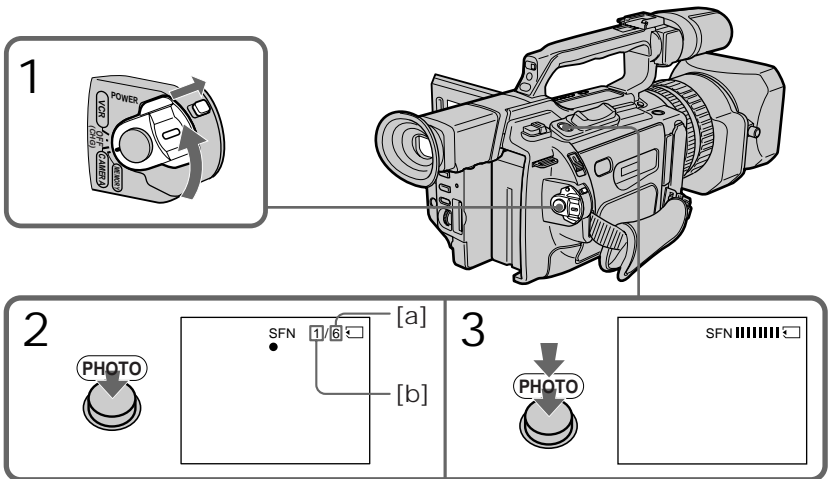

[a] The number of images that can be recorded on the “Memory Stick”

[b] The number of recorded images

When the POWER switch is set to MEMORY

The following functions do not work: wide TV mode, digital effect, picture effect, title, digital zoom, fader, shutter speed (1/30 or smaller) adjustment, and low lux mode and sports lesson mode in PROGRAM AE. (The indicator flashes in the low lux or sports lesson mode.)

Note

When you press the PHOTO button lightly at step 2, the focus of the image seems to be momentarily out.

Recording still images on a “Memory Stick” – Memory Photo recording

While you are recording a still image
You can neither turn off the power nor press PHOTO.

When you press PHOTO on the Remote Commander
Your camcorder immediately records the image that is on the screen when you press the button.

Recording images continuously

You can record still images continuously. Select one of the two modes described below before recording.

Continuous mode [a]

You can four record still images continuously. The number of images is in accordance with remaining capacity of the “Memory Stick.”

Multi screen mode [b]

You can record nine still images continuously on a single page.

[a]

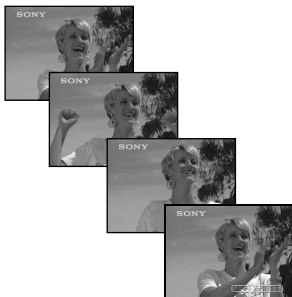

[b]





While pressing down PHOTO, the camcorder shoots still images continuously. The maximum number of recordable still images is up to four. If you release the button during shooting, the recording stops even if it is in progress.

Recording still images on a "Memory Stick" – Memory Photo recording

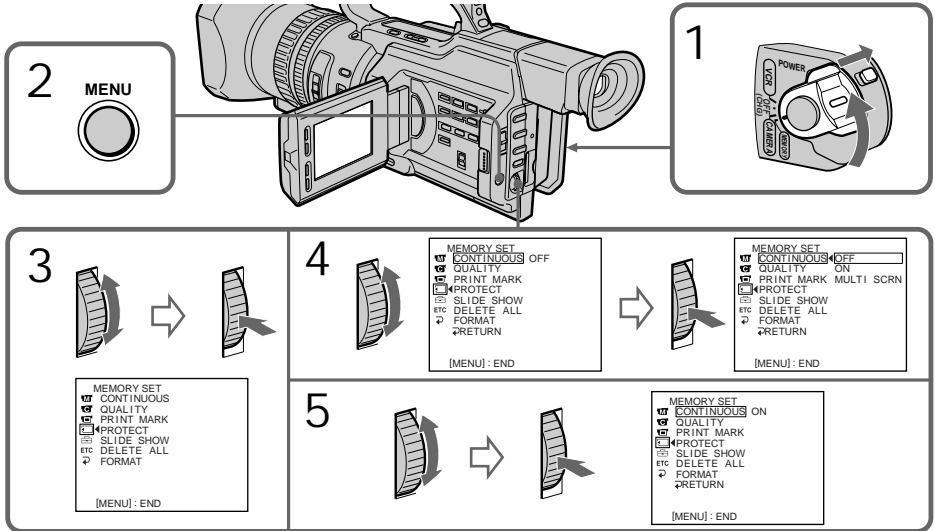
- (1) Set the POWER switch to MEMORY. Make sure that the LOCK switch is set to the right (unlock) position.
- (2) Press MENU to display the menu.
- (3) Turn the SEL/PUSH EXEC dial to select , then press the dial.
- (4) Turn the SEL/PUSH EXEC dial to select CONTINUOUS, then press the dial.
- (5) Turn the SEL/PUSH EXEC dial to select the desired setting, then press the dial.



Continuous shooting settings

Setting	Meaning (indicator on the screen)
OFF	Your camcorder shoots one image at a time. (no indicator)
ON	Your camcorder shoots four still images at about 0.5 sec intervals. ()
MULTI SCR	Your camcorder shoots nine still images at about 0.5 sec intervals and displays the images on a single page divided into nine boxes. ()

If the capacity of the "Memory Stick" becomes full "FULL" appears on the screen, and you cannot record still pictures on this "Memory Stick."

The number of images in continuous shooting
 The number of images you can shoot continuously varies depending on the remaining capacity of the "Memory Stick." The shutter always clicks four times, however, the number of images recordable may be less than four.

Recording still images on a "Memory Stick" – Memory Photo recording

Note on using a video flash light (not supplied)



The video flash light does not work in the continuous or multi screen mode if you install it to the intelligent accessory shoe.

When shooting with the self-timer function or the Remote Commander

The camcorder automatically records up to the maximum recordable number of still pictures.

Self-timer memory photo recording



You can make a memory photo recording with the self-timer. This mode is useful when you want to record yourself. You can also use the Remote Commander.

- (1) Set the POWER switch to MEMORY. Make sure that the LOCK switch is set to the right (unlock) position.
- (2) Press  (self-timer) in standby mode. The  (self-timer) indicator appears on the LCD screen or in the viewfinder.
- (3) Press PHOTO deeply.

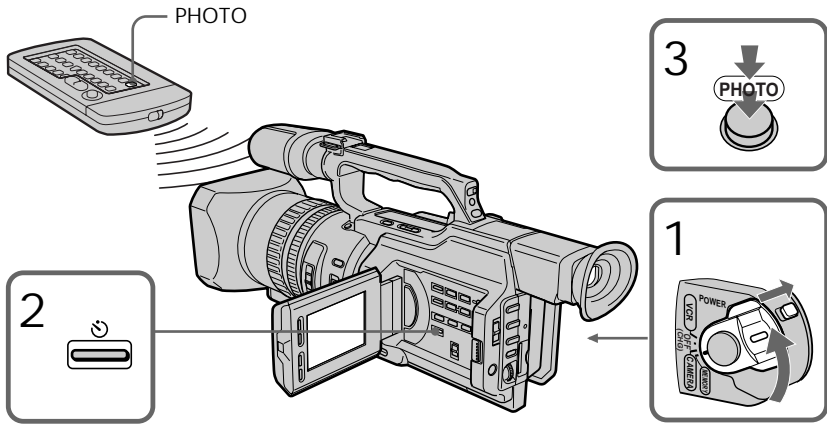
The self-timer starts counting down from 10 with a beep sound. In the last two seconds of the countdown, the beep sound gets faster, then recording starts automatically.



To cancel self-timer recording

Press  (self-timer) so that the  indicator disappears from the LCD or viewfinder screen. You cannot cancel the self-timer recording using the Remote Commander.

Note

The self-timer recording mode is automatically canceled when:

- Self-timer recording is finished.
- The POWER switch is set to OFF (CHG) or VCR.

Superimposing a still image in a “Memory Stick” on a moving picture – MEMORY MIX

You can superimpose a still image you have recorded on a “Memory Stick” on the top of the moving picture you are recording.

M. CHROM (Memory chromakey)

You can swap a blue area of a still image such as an illustration or a frame with a moving picture.

M. LUMI (Memory luminancekey)

You can swap a brighter area of a still image such as a handwritten illustration or title with a moving picture. Record a title on a “Memory Stick” before a trip or event for convenience.

C. CHROM (Camera chromakey)

You can superimpose a moving picture on a still image that used as background. Shoot the subject against a blue background. The blue area of the moving picture will be swapped with a still image.

M. OVERLAP (Memory overlap)

You can make a moving picture fade in on top of a still image.

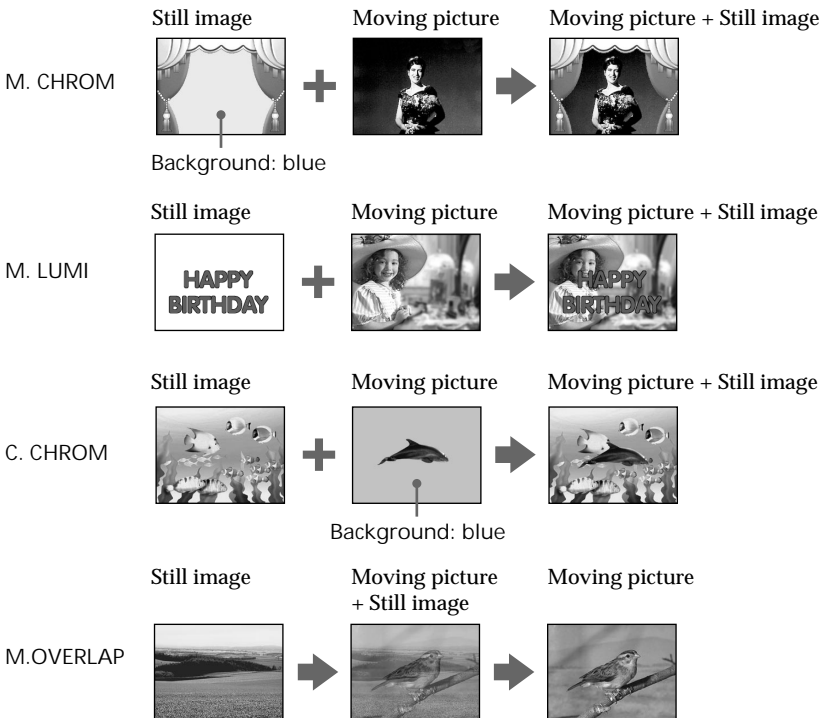

Superimposing a still image in a "Memory Stick" on a moving picture – MEMORY MIX

Before operation

Insert a recorded "Memory Stick" and a mini DV tape to be recorded into your camcorder.

(1) Set the POWER switch to CAMERA.

(2) Press MEMORY MIX in standby mode.

The last recorded or last composed image appears on the lower part of the screen as a thumbnail image.

(3) Press MEMORY+/- or +/- on the Remote Commander to select the still image you want to superimpose.

To see the previous image, press MEMORY - or - on the Remote Commander.

To see the next image, press MEMORY+ or + on the Remote Commander.

(4) Turn the SEL/PUSH EXEC dial to select the desired mode.

The mode changes as follows:

M. CHROM ↔ M. LUMI ↔ C. CHROM ↔ M. OVERLAP

(5) Press the SEL/PUSH EXEC dial.

The still image is superimposed on the moving picture, and your camcorder is in standby mode.

(6) Turn the SEL/PUSH EXEC dial to adjust the effect.

(7) Press START/STOP to start recording.

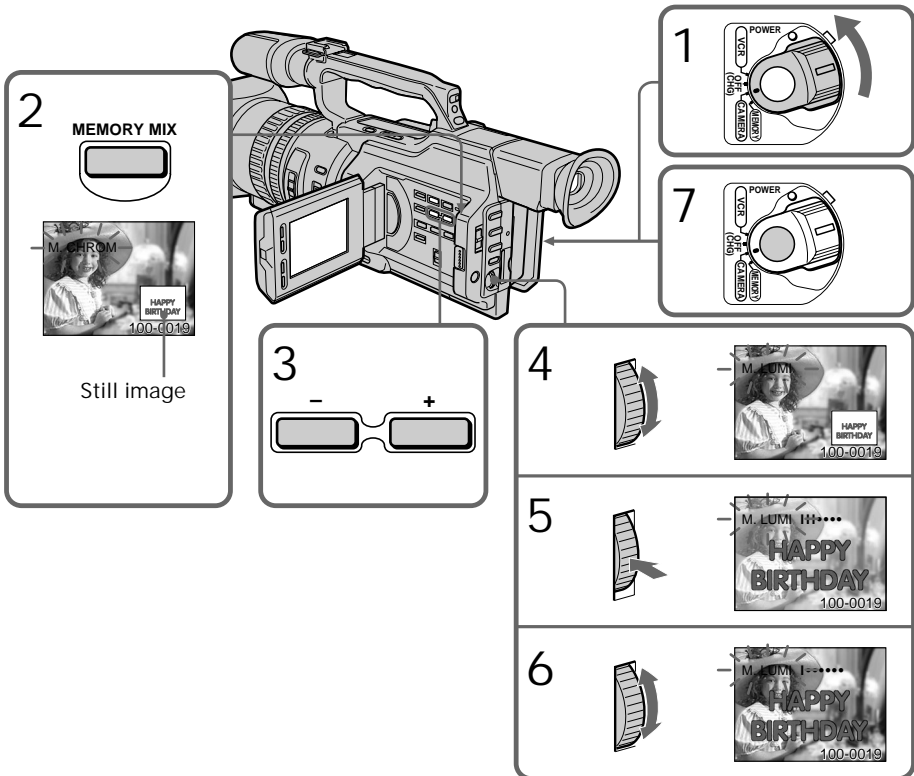

Superimposing a still image in a “Memory Stick” on a moving picture – MEMORY MIX

Items to be adjusted

M. CHROM	The color (blue) scheme of the area in the still picture which is to be swapped with a moving picture
M. LUMI	The color (bright) scheme of the area in the still picture which is to be swapped with a moving picture
C. CHROM	The color (blue) scheme of the area in the moving picture which is to be swapped with a still picture
M. OVERLAP	No adjustment necessary

As the bar is shorter, the effect is enhanced.

To change the still image to be superimposed

Do either of the following:

- Press MEMORY+/- after step 6.
- Press the SEL/PUSH EXEC dial after step 6, and repeat the procedure from step 4 (except M. OVERLAP).

To change the mode setting

Press SEL/PUSH EXEC dial after step 6, and repeat the procedure from step 4 (except M. OVERLAP).

To cancel MEMORY MIX

Press MEMORY MIX.

During recording

You cannot change the mode setting.

The “Memory Stick” supplied with your camcorder has 20 images stored

- For M. CHROM: 18 images (such as a frame) 100-0001 to 100-0018
- For C. CHROM: two images (such as background) 100-0019 to 100-0020

Sample images

Sample images stored in the “Memory Stick” supplied with your camcorder are protected (p. 138).

If a still image to be superimposed has lots of white areas

The thumbnail image may not be displayed clearly.

Image data modified with personal computers or shot with other equipment

You may not be able to play them back with your camcorder.

Recording an image from a mini DV tape as a still image

Your camcorder can read moving picture data recorded on a mini DV tape and record it as a still image on a “Memory Stick.” Your camcorder can also take in moving picture data through the input connector and record it as a still image on a “Memory Stick.”

Before operation

Insert a recorded mini DV tape and a “Memory Stick” into your camcorder.

- (1) Set the POWER switch to VCR.
- (2) Press **▶**. The picture recorded on the mini DV tape is played back.
- (3) Keep pressing PHOTO lightly until the picture from the mini DV tape freezes. “CAPTURE” appears on the LCD screen or in the viewfinder. Recording does not start yet.
- (4) Press PHOTO deeper. The image displayed on the screen will be recorded on a “Memory Stick.” Recording is complete when the bar scroll indicator disappears.

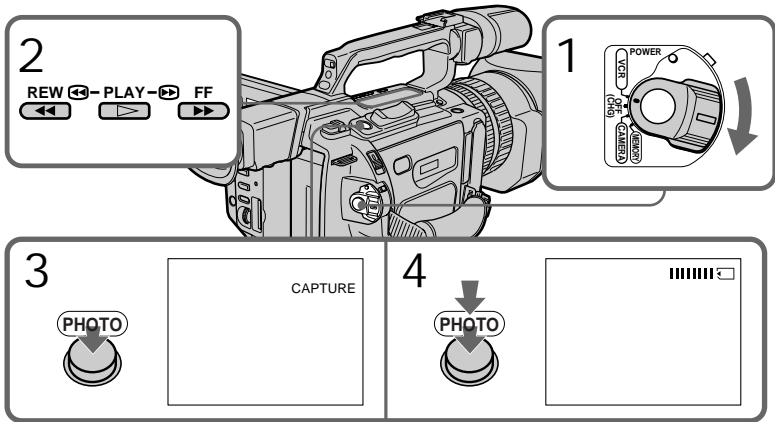

“Memory Stick” Operations

When the access lamp is lit or is flashing

Never shake or strike the unit. Also, do not turn the power off, eject a “Memory Stick” or remove the battery pack. Otherwise, image data breakdown may occur.

If “” appears on the LCD screen or in the viewfinder

The inserted “Memory Stick” is incompatible with your camcorder because its format does not conform to that of your camcorder. Check the format of the “Memory Stick.”

If you press PHOTO lightly in the playback mode
The playback pauses momentarily.

Sound recorded on a mini DV tape

You cannot record the sound from a mini DV tape.

Recording an image from a mini DV tape as a still image

Titles that are already recorded on mini DV tapes
You cannot record the titles on a "Memory Stick."

When you press PHOTO on the Remote Commander
Your camcorder immediately records the image that is on the screen when you press the button.

Recording a still image from other equipment

- (1) Set the POWER switch to VCR on your camcorder and set DISPLAY in **ETC** to LCD in the menu settings.
- (2) Play back the recorded tape, or turn the TV on to see the desired program. The picture from the other equipment appears on the LCD screen or in the viewfinder.
- (3) Follow steps 3 and 4 on page 127.

When recording an image through the VIDEO jack

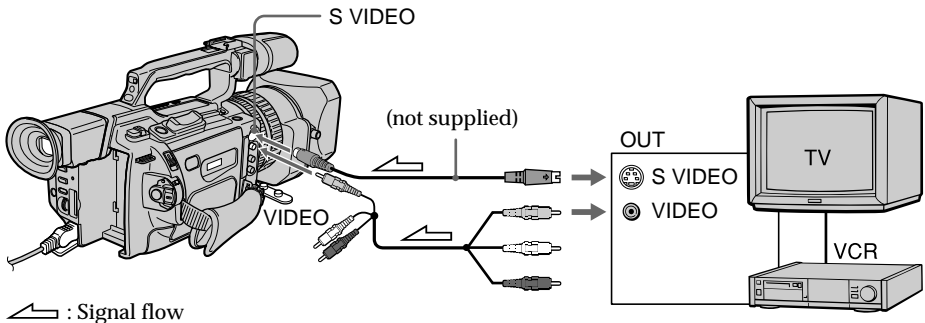

Connect the yellow plug of the A/V connecting cable supplied with your camcorder to the video output jack on the VCR or the TV.

Connect using an S video cable (not supplied) to obtain high-quality pictures
With this connection, you do not need to connect the yellow (video) plug of the A/V connecting cable.

Connect an S video cable (not supplied) to the S video jacks of both your camcorder and the VCR/TV.

This connection produces higher quality DV format pictures.

Recording an image from a mini DV tape as a still image

When recording the image through the DV IN/OUT jack

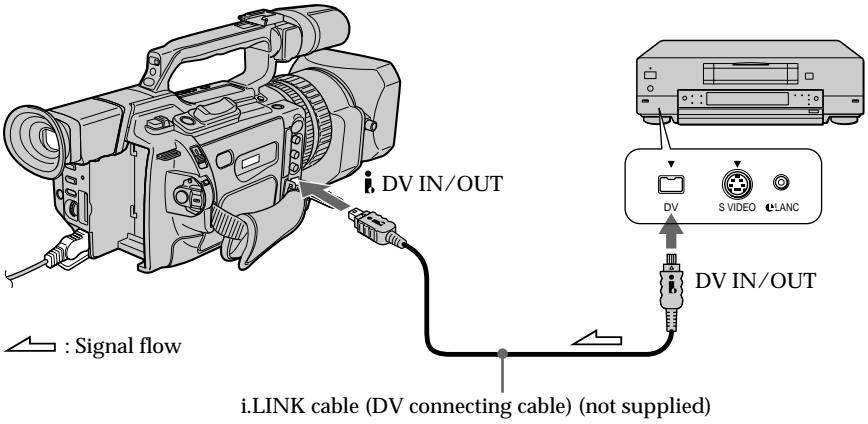

Copying still images from a mini DV tape – Photo save

Using the search function, you can automatically take in only still images from mini DV tapes and record them on a “Memory Stick” in sequence.

Before operation

- Insert a recorded mini DV tape into your camcorder and rewind the tape.
- Insert a “Memory Stick” into your camcorder.

- (1) Set the POWER switch to VCR.
- (2) Press MENU to display the menu.
- (3) Turn the SEL/PUSH EXEC dial to select , then press the dial.
- (4) Turn the SEL/PUSH EXEC dial to select PHOTO SAVE, then press the dial. “PHOTO BUTTON” appears on the LCD screen or in the viewfinder.
- (5) Press PHOTO deeply. The still image from the mini DV tape is recorded on the “Memory Stick.” The number of still images copied is displayed. “END” is displayed when copying is completed.

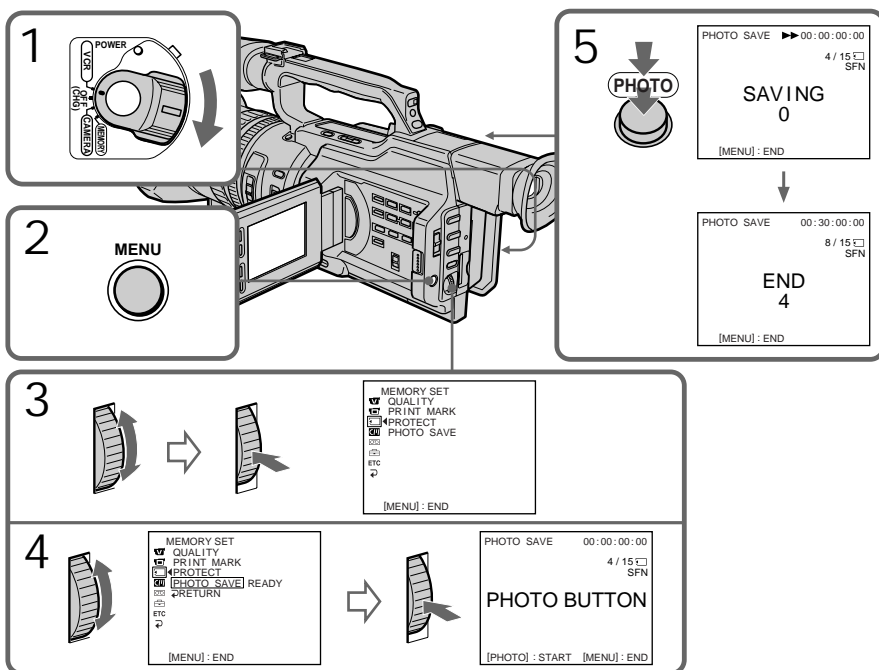

Copying still images from a mini DV tape – Photo save

To cancel copying

Press MENU.

When the memory of the “Memory Stick” is full

“MEMORY FULL” appears on the LCD screen or in the viewfinder, and the copying stops. Insert another “Memory Stick” and repeat the procedure from step 2.

When the access lamp is lit or flashing

Never shake or strike your camcorder. Also, do not turn the power off, eject the “Memory Stick” or remove the battery pack. Otherwise, the image data breakdown may occur.

To record all the images recorded on the mini DV tape

Rewind the tape all the way back and start copying.

If the write-protect tab on the “Memory Stick” is set to LOCK

“NOT READY” appears when you select the item in the menu settings.

When you change the “Memory Stick” in the middle of copying

Your camcorder resumes copying from the last image recorded on the previous “Memory Stick.”

Viewing a still picture – Memory Photo playback

You can play back still images recorded on a “Memory Stick.” You can also play back six images at a time by selecting the index screen.

Before operation

Insert a “Memory Stick” into your camcorder.

- (1) Set the POWER switch to VCR or MEMORY. Make sure that the LOCK switch is set to the right (unlock) position.
- (2) Press MEMORY PLAY. The last recorded image is displayed.
- (3) Press MEMORY +/- or +/- on the Remote Commander to select the desired still image. To see the previous image, press MEMORY - or - on the Remote Commander. To see the next image, press MEMORY + or + on the Remote Commander.

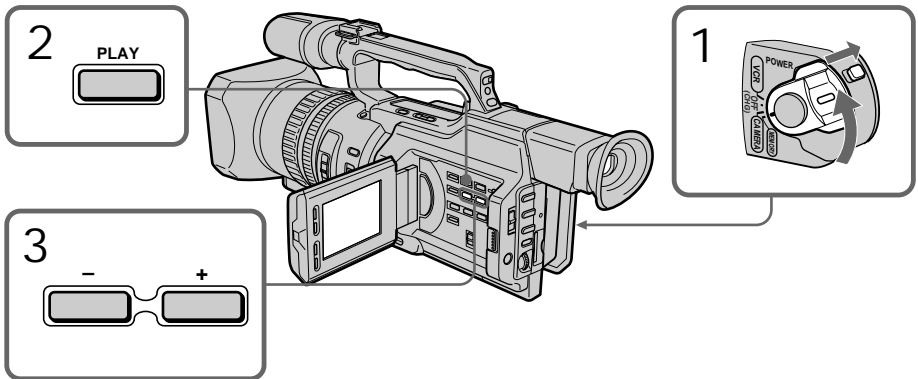

To stop memory photo playback
Press MEMORY PLAY again.

To play back recorded images on a TV screen

- Connect your camcorder to the TV with the A/V connecting cable supplied with your camcorder before operation.
- When operating memory photo playback on a TV or on the LCD screen, the image quality may appear to have deteriorated. This is not a malfunction. The image data is as good as ever.
- Turn the volume of the TV down before operation, or noise (howling) may be output from the TV speakers.

When no images are recorded on the “Memory Stick”
The message “ NO FILE” appears.

Image data modified with personal computers or shot with other equipment
You may not be able to play them back with your camcorder.

Note on the date/time indicator

Recording date/time is not displayed, however, it is automatically recorded on the “Memory Stick.” You can check the recording date/time while in memory playback mode by pressing DATA CODE.

Viewing a still picture – Memory Photo playback

Screen indicators during still image playback

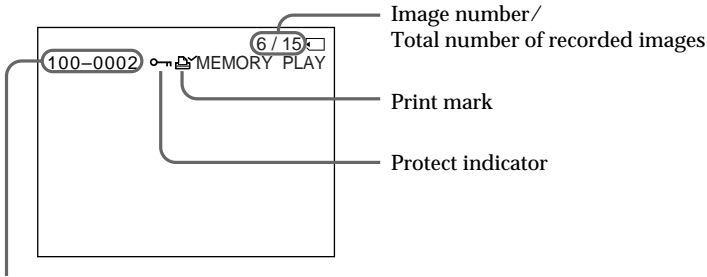

Data file name

On data file name

- When the hyphen is indicated between the directory and the file number, this data file name means that this file corresponds to the DCF98 standard.
- When the underbar is indicated between the directory and the file number, this data file name means that this file does not correspond to the DCF98 standard.
- The directory is not indicated if the file structure in the “Memory Stick” does not correspond to the DCF98 standard.
- The “ DIRECTORY ERROR” message may appear if the file structure in the “Memory Stick” does not correspond to the DCF98 standard. In this case, you cannot record on that “Memory Stick,” however, you can play back images in the “Memory Stick.”
- When the data file name is flashes, the file may be broken or the file format does not correspond to your camcorder.

Playing back six recorded images at a time (index screen)

You can play back six recorded images at a time. This function is especially useful when searching for a particular image.

- (1) Set the POWER switch to VCR or MEMORY. Make sure that the LOCK switch is set to the right (unlock) position.
- (2) Press MEMORY INDEX to display the index screen.

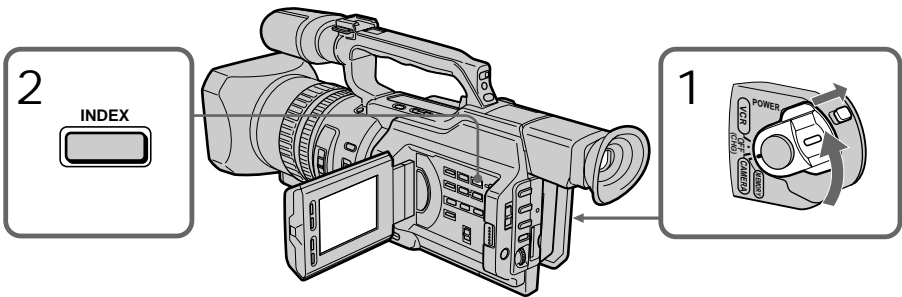

Viewing a still picture – Memory Photo playback

A red ► mark appears above the image that is displayed before changing to the index screen mode.

MEMORY – : to display the previous six images

MEMORY + : to display the following six images

If you select the desired image by turning the SEL/PUSH EXEC dial, then press the dial, the selected image will be displayed on full screen.

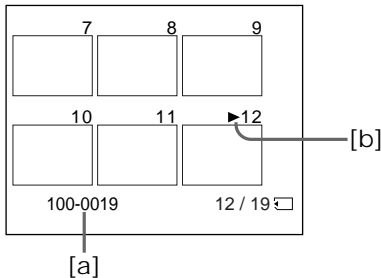

[a] File name

[b] ► mark

To return to the normal playback screen (single screen)

Press MEMORY +/- to move the ► mark to the image you want to display on full screen, then press MEMORY PLAY.

Files modified with personal computers

These files may not be displayed on the index screen. Image files shot with other equipment may not be displayed on the index screen either.

Note

When displaying the index screen, a number appears above each image. This indicates the order in which images are recorded on the “Memory Stick.” These numbers are different from the data file names.

Viewing the recorded images using a personal computer

The image data recorded with your camcorder is compressed in the JPEG format. If you use the application software, “PictureGear 4.1Lite” supplied with your camcorder, you can see images recorded on a “Memory Stick” on a computer screen. Use the Memory Stick Reader/Writer supplied with your camcorder, the Memory Stick/PC card kit or PC card adaptor for Memory Stick (not supplied) for this operation. For detailed instructions on operation, refer to the operating instructions of the serial port adaptor, Memory Stick/PC card kit or PC card adaptor for Memory Stick and your application software. For details, refer to the operating instructions of your accessory.

- Do not modify the directory of the file that corresponds to the DCF98 standard. The modified file will not be read.
- If you use the new “Memory Stick,” be sure to use it first with this camcorder.

Recommended Windows environment

- OS: Microsoft Windows 98 standard installation
Operation in an environment upgraded to Windows 98 is not assured.
- CPU: MMX Pentium 200 MHz or faster

Recommended Macintosh environment

- OS: Mac OS system 8.5/8.6 standard installation
- Model: iMac/G3

Copying an image recorded on a “Memory Stick” to mini DV tapes

You can copy still images or titles recorded on a “Memory Stick” to a mini DV tape.

Before operation

Insert a mini DV tape for recording and a “Memory Stick” for playback into your camcorder.

- (1) Set the POWER switch to VCR.
- (2) Using the video control buttons, search for a point where you want to record the desired still image. Set the mini DV tape to playback pause mode.
- (3) Press ● REC and the button on its right simultaneously on your camcorder. The mini DV tape is set to the recording pause mode.
- (4) Press MEMORY PLAY to play back the still image you want to copy.
- (5) Press ■ to start recording and press ■ again to stop.
- (6) If you have more to copy, repeat steps 4 and 5.

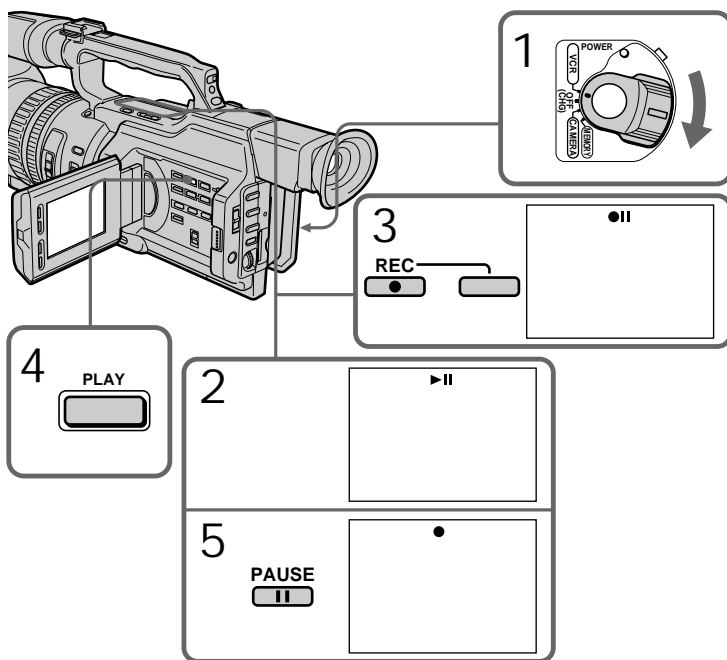

To stop copying in the middle
Press ■.

During copying

- You cannot operate the following buttons:
MEMORY PLAY, MEMORY INDEX, MEMORY DELETE, MEMORY +, MEMORY -,
and MEMORY MIX.
- If you continue copying, do not use EDITSEARCH to search for the point where you want to record the desired still image. If you do, the playback image disappears from the screen.

Copying an image recorded on a "Memory Stick" to mini DV tapes

Note on the index screen

You cannot record the index screen.

Image data modified with personal computers or shot with other equipment

You may not be able to copy them with your camcorder.

If you press DISPLAY in standby or recording mode

You can see memory playback and the file name indicators in addition to the indicators pertinent to mini DV tapes, such as the time code indicator.

Playing back images continuously – SLIDE SHOW

You can automatically play back images in sequence. This function is useful especially when checking recorded images or during a presentation.

Before operation

Insert a “Memory Stick” into your camcorder.

- (1) Set the POWER switch to MEMORY. Make sure that the LOCK switch is set to the right (unlock) position.
- (2) Press MENU to display the menu.
- (3) Turn the SEL/PUSH EXEC dial to select , then press the dial.
- (4) Turn the SEL/PUSH EXEC dial to select SLIDE SHOW, then press the dial.
- (5) Press MEMORY PLAY. Your camcorder plays back the images recorded on the “Memory Stick” in sequence.

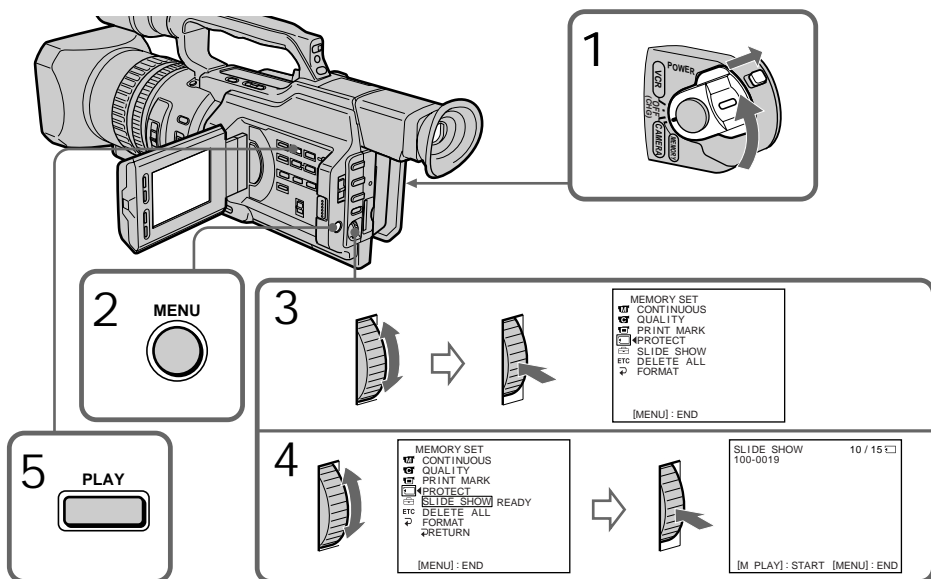

To stop or end the slide show
Press MENU.

To pause during a slide show
Press MEMORY PLAY.

To start the slide show from a particular image
Select the desired image using MEMORY +/- buttons before step 2.

To view the recorded images on TV

Connect your camcorder to a TV with the A/V connecting cable supplied with your camcorder before operation.



If you change the “Memory Stick” during operation
Be sure to follow the steps again from the beginning.

Preventing accidental erasure – Image protection

To prevent accidental erasure of important images, you can protect selected images.

Before operation

Insert a “Memory Stick” into your camcorder.

- (1) Set the POWER switch to MEMORY or VCR. Make sure that the LOCK switch is set to the right (unlock) position.
- (2) Play back the image you want to protect (p. 132).
- (3) Press MENU to display the menu.
- (4) Turn the SEL/PUSH EXEC dial to select , then press the dial.
- (5) Turn the SEL/PUSH EXEC dial to select PROTECT, then press the dial.
- (6) Turn the SEL/PUSH EXEC dial to select ON, then press the dial.
- (7) Press MENU to erase the menu display. The “” mark is displayed beside the data file name of the protected image.

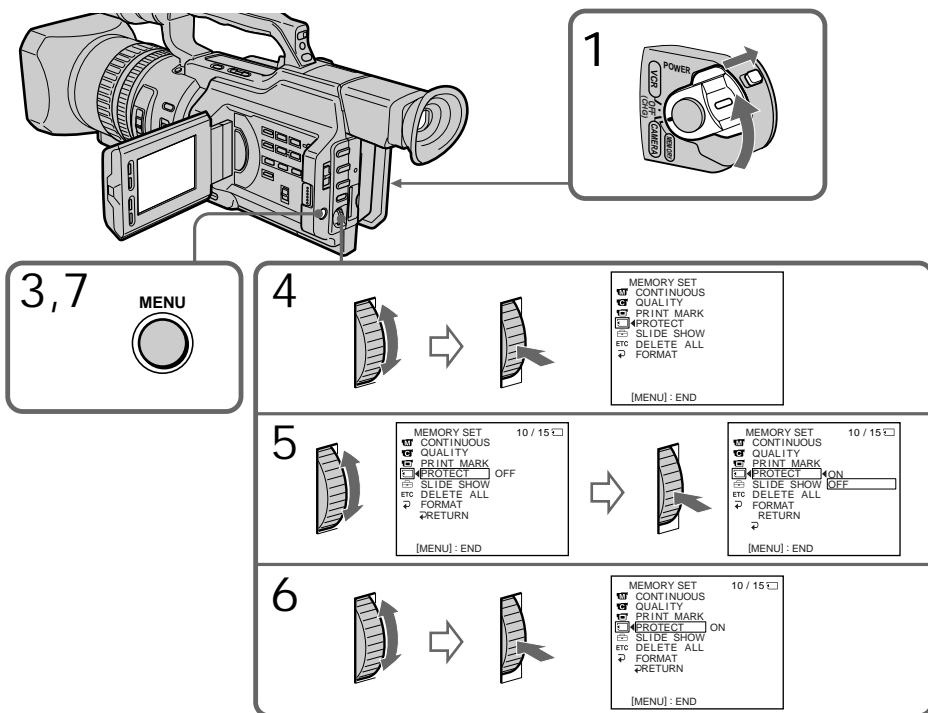

To cancel image protection

Select OFF in step 6, then press the SEL/PUSH EXEC dial.

Note

Formatting erases all information on the “Memory Stick,” including the protected image data. Check the contents of the “Memory Stick” before formatting.

If the write-protect tab on the “Memory Stick” is set to LOCK
You cannot carry out image protection.

Deleting images

You can delete images stored in a “Memory Stick.”

Deleting selected images

Before operation

Insert a “Memory Stick” into your camcorder.

- (1) Set the POWER switch to MEMORY or VCR. Make sure that the LOCK switch is set to the right (unlock) position.
- (2) Play back the image you want to delete (p. 132).
- (3) Press MEMORY DELETE. “DELETE?” appears on the LCD screen or in the viewfinder.
- (4) Press MEMORY DELETE again. The selected image is deleted.

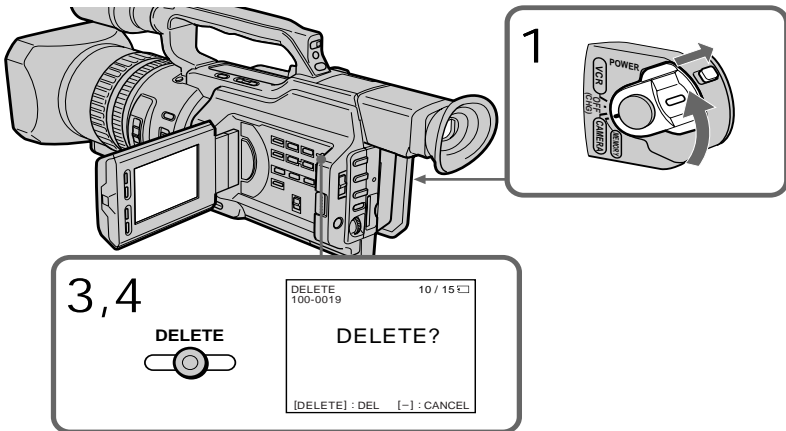

“Memory Stick” Operations

To cancel deleting an image

Press MEMORY – in step 4.

To delete an image displayed on the index screen

Press MEMORY +/- to move the ► mark to the desired image and follow steps 3 and 4.

Notes

- To delete a protected image, first cancel image protection.
- Once you delete an image, you cannot restore it. Check the images to be deleted carefully before deleting them.

While “DELETING” appears

Do not turn the POWER switch or press any buttons.

If the write-protect tab on the “Memory Stick” is set to LOCK

You cannot delete any image.

Deleting images

Deleting all the images

You can delete all the unprotected images in a “Memory Stick.”

Before operation
Insert a “Memory Stick” into your camcorder.

- (1) Set the POWER switch to MEMORY. Make sure that the LOCK switch is set to the right (unlock) position.
- (2) Press MENU to display the menu.
- (3) Turn the SEL/PUSH EXEC dial to select , then press the dial.
- (4) Turn the SEL/PUSH EXEC dial to select DELETE ALL, then press the dial.
- (5) Turn the SEL/PUSH EXEC dial to select OK, then press the dial. “OK” changes to “EXECUTE.”
- (6) Press the SEL/PUSH EXEC dial. “DELETING” appears on the LCD screen or in the viewfinder. When all the unprotected images are deleted, “COMPLETE” is displayed.

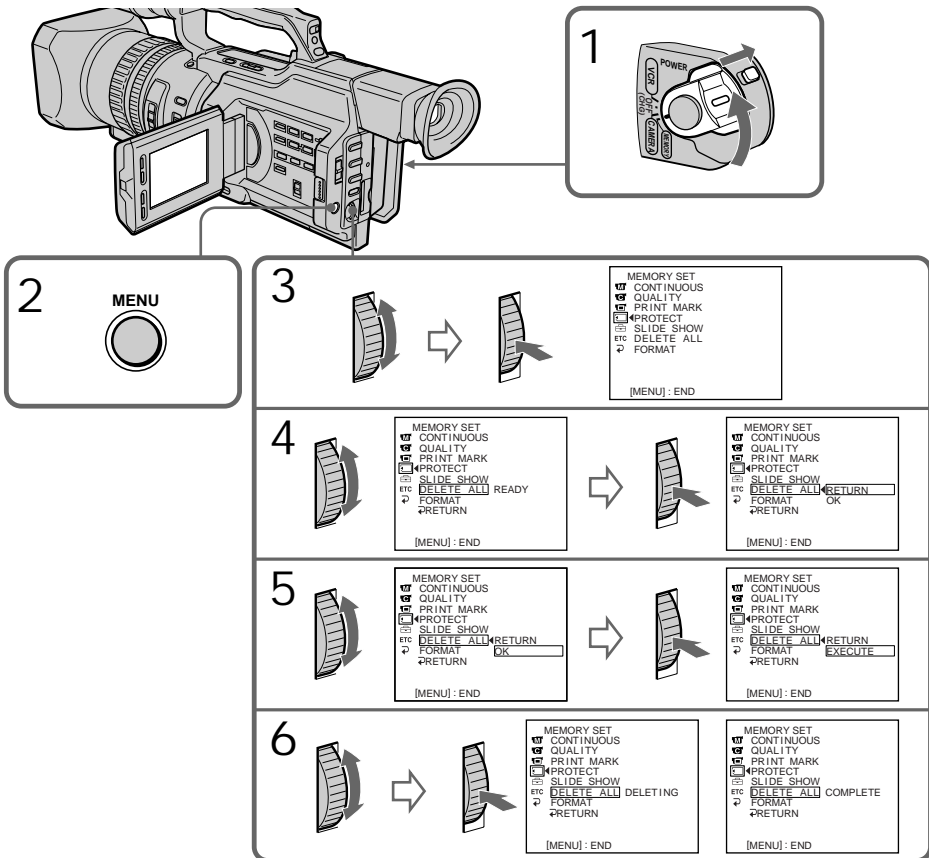

Deleting images

To cancel deleting all the images in the "Memory Stick"
Select RETURN in step 5 or 6, then press the SEL/PUSH EXEC dial.



Writing a print mark – Print mark

You can specify the recorded still image to be printed out. This function is useful for printing out still images later.

Your camcorder conforms with the DPOF (Digital Print Order Format) standard for specifying the still images to print out.

Before operation

Insert a “Memory Stick” into your camcorder.

- (1) Set the POWER switch to MEMORY or VCR. Make sure that the LOCK switch is set to the right (unlock) position.
- (2) Play back the image to be printed out (p. 132).
- (3) Press MENU to display the menu.
- (4) Turn the SEL/PUSH EXEC dial to select , then press the dial.
- (5) Turn the SEL/PUSH EXEC dial to select PRINT MARK, then press the dial.
- (6) Turn the SEL/PUSH EXEC dial to select ON, then press the dial.
- (7) Press MENU to erase the menu display. The “” mark is displayed beside the data file name of an image.

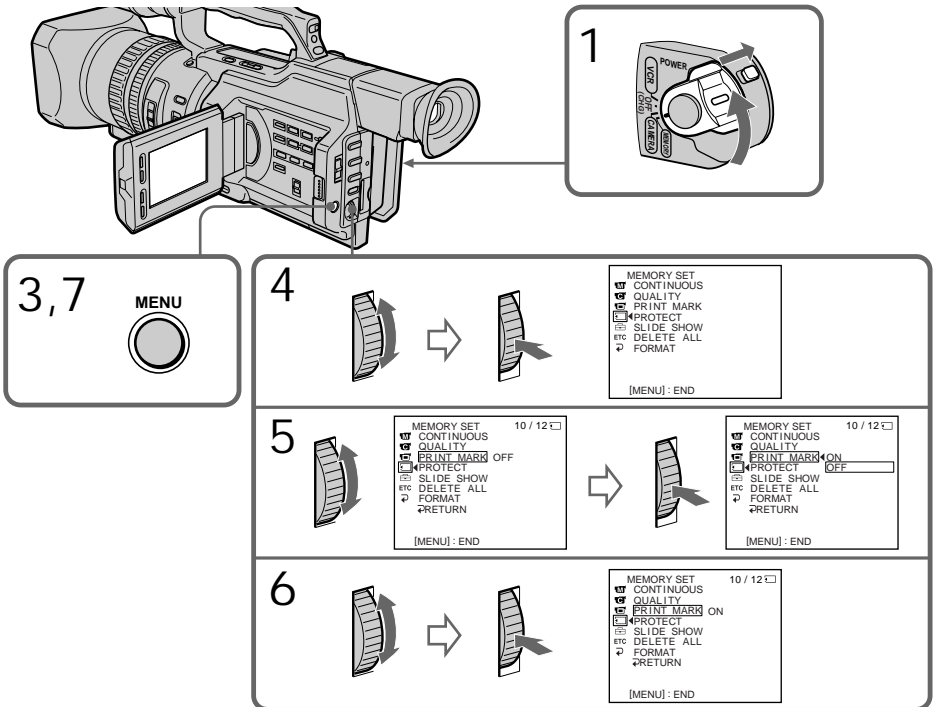

To cancel writing print marks

Select OFF in step 6, then press the SEL/PUSH EXEC dial.

If the write-protect tab on the “Memory Stick” is set to LOCK
You cannot write print marks on still images.

Usable cassettes

Selecting cassette types

You can use the ^{Mini}**DV** mini DV cassette only*. You cannot use any other **8** 8 mm, **Hi8** Hi8, **D** Digital8, **VHS** VHS, **VHS-C** VHSC, **S-VHS** S-VHS, **S-VHS-C** S-VHSC, **B** Betamax, **ED Beta** ED Betamax or **DV** DV cassette.

* There are two types of mini DV cassettes: with cassette memory and without cassette memory. Tapes with cassette memory have **CM** (Cassette Memory) mark. Sony recommends that you use a tape with **CM** mark to enjoy your camcorder fully.

The IC memory is built in the cassette with cassette memory. Using this IC memory, your camcorder can read, write, and search data such as the date of recording or titles. The functions using the cassette memory require successive signals recorded on the tape. If the tape has a blank portion in the beginning or between the recorded portions, a title may not be displayed properly or the search functions may not work correctly. Not to make any blank portion on the tape, press END SEARCH to return to the end of the recorded portion before you begin the next recording when:

- You have ejected the cassette while recording.
- You have played back the tape in VCR mode.

If there is a blank portion or discontinuous signal on your tape, re-record from the beginning to the end of the tape concerning above.

When you record, using a digital video camera recorder without a cassette memory function, on a tape recorded by one with the cassette memory function, the same result may occur.

CM4K mark on the cassette

The memory capacity of tapes marked with **CM4K** is 4 Kb. Your camcorder can accommodate up to 16 Kb. 16 Kb tape is marked with **CM16K**.

The maximum number of data recordable on cassette memory (when using 4 Kb cassette memory)

Data	Numbers
INDEX	32
TITLE	25
DATE	6 (10 bytes/1 data)
PHOTO	12 (10 bytes/1 data)
CASSETTE LABEL	1 (6 bytes/1 data)

Copyright signal

When you play back

When you connect your camcorder to any other video camera recorder to dub a tape that has recorded copyright control signals for copyright protection, you may not record the tape that played back on your camcorder.

When you record

You cannot record software on your camcorder that contains copyright control signals for copyright protection of software.

"COPY INHIBIT" appears on the LCD screen, in the viewfinder or on the TV screen if you try to record such software.

Your camcorder does not record copyright control signals on the tape when it records.

Usable cassettes

Audio mode

12-bit mode: The original sound can be recorded in stereo 1, and the new sound in stereo 2 in 32 kHz. The balance between stereo 1 and stereo 2 can be adjusted by selecting AUDIO MIX in the menu settings during playback. Both sounds can be played back.

16-bit mode: A new sound cannot be recorded but the original sound can be recorded in high quality. Moreover, it can also play back sound recorded in 32 kHz, 44.1 kHz or 48 kHz. When playing back a tape recorded in the 16-bit mode, 16BIT indicator appears on the LCD screen or in the viewfinder.

When you play back a dual sound track tape

When you play back a dual sound track tape recorded in a stereo system, set HiFi SOUND to the desired mode in the menu settings (p. 107).

Sound from speaker

HiFi SOUND mode	Playing back a stereo tape	Playing back a dual sound track tape
STEREO	Stereo	Main sound and sub sound
1	Left sound	Main sound
2	Right sound	Sub sound

You cannot record dual sound programs on your camcorder.

Notes on the mini DV cassette

When affixing a label on the mini DV cassette

Be sure to affix a label only on the locations as illustrated below [a] so as not to cause malfunction of your camcorder.

After using the mini DV cassette

Rewind the tape to the beginning, put the cassette in its case, and store it in an upright position.

If the cassette memory function does not work

Reinsert a cassette a few times. The gold-plated connector of mini DV cassettes may be dirty or dusty.

Cleaning the connector

If the gold-plated connector of mini DV cassettes is dirty or dusty, you may not operate the function using cassette memory. Clean up the gold-plated connector with cotton-wool swab, about every 10 times ejection of a cassette. [b]

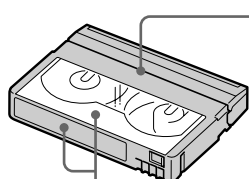

Do not affix a label around this border.

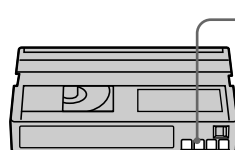

About i.LINK

Your camcorder is equipped with the DV input/output connector based on i.LINK (IEEE1394) standard.

This section explains the specifications and features of i.LINK.

What is i.LINK?

i.LINK is a digital serial interface designed to integrate the devices equipped with i.LINK connector. By connecting i.LINK devices, i.LINK allows your device to:

- Transmit and receive data such as digital audio and digital video signals in two ways
- Control other i.LINK devices
- Easily connect with another device using just an i.LINK cable.

Your i.LINK device is capable of connecting AV devices and perform various operations and data transfer. Further availability for connections with versatile equipment and operations will be planned in the future.

Other advantages include the following feature. When connecting multiple i.LINK devices, your device cannot only perform operations and data transfer with the directly connected device but also perform them with any of the devices that are connected via other devices. Therefore, you will not need to concern the order of connecting devices. However, depending on the features and specifications of the connected devices, you may need to operate certain functions differently or may not be able to perform certain operations or data transfer.

Note

Your camcorder can be connected to one device with the i.LINK cable (DV cable). When you connect with a device that has two or more i.LINK connectors, refer to the operating instructions supplied with the connected device.

Tips

- i.LINK, a nickname for IEEE 1394 that Sony proposed, is a trademark supported by a majority of companies worldwide.
- IEEE 1394 is an international standard defined by IEEE, The Institute of Electrical and Electronics Engineers, Inc.

About data transfer speed of i.LINK

i.LINK defines a maximum data transfer speed of approximately 100, 200 and 400 Mbps* that are described as S100, S200 and S400 respectively.

For i.LINK devices, a maximum data transfer speed that the device supports is identified on "Specifications" page of the operating instructions supplied with the device or near its i.LINK connector.

With a device that does not identify the data transfer speed, the maximum data transfer speed that the device supports is S100.

When connecting with the device that support different data transfer speed, the actual data transfer speed may be different from those described on the i.LINK connectors.

*What is Mbps?

Mega bits per second. A measure of the rate at which data is transmitted per second. In case of 100 Mbps, 100 Mega bits of data can be transmitted per second.

i.LINK operation with your camcorder

For details on dubbing your camcorder to your VCR equipped with DV input/output connector, see page 74, 89.

Your camcorder is available for use with other devices equipped with Sony i.LINK (DV) connector (eg. VAIO personal computer series).

For details on connection with i.LINK cable and necessary software, refer to the operating instructions supplied with the connected device.

Use Sony i.LINK cables

Use Sony i.LINK cables to connect the i.LINK devices.

4 pins ↔ 4 pins (For dubbing)

i.LINK and  are trademarks.

Troubleshooting

If you run into any problem using your camcorder, use the following table to troubleshoot the problem. If the problem persists, disconnect the power source and contact your Sony dealer or local authorized Sony service facility. If “C:□□:□□” appears on the LCD screen, display window or in the viewfinder, the self-diagnosis display function has worked. See page 152.

In the recording mode

Symptom	Cause and/or Corrective Actions
START/STOP does not operate.	<ul style="list-style-type: none">• The POWER switch is not set to CAMERA. → Set it to CAMERA. (p. 15)• The tape has run out. → Rewind the tape or insert a new one. (p. 14, 29)• The write-protect tab on the cassette is set to expose the red mark. → Use a new tape or slide the tab. (p. 14)• The tape is stuck to the drum (moisture condensation). → Remove the cassette and leave your camcorder for at least one hour to acclimatize. (p. 156)
The power goes off.	<ul style="list-style-type: none">• While being operated in CAMERA mode, your camcorder has been in the standby mode for more than five minutes. → Set the POWER switch to OFF (CHG) and then to CAMERA again. (p. 16)• The battery pack is dead or nearly dead. → Install a charged battery pack. (p. 9, 10)
The image on the viewfinder screen is not clear.	<ul style="list-style-type: none">• The viewfinder lens is not adjusted. → Adjust the viewfinder lens. (p. 19)
The SteadyShot function does not work.	<ul style="list-style-type: none">• STEADYSHOT is set to OFF in the menu settings. → Set it to ON. (p. 107)
The autofocus function does not work.	<ul style="list-style-type: none">• The camcorder is in manual focus mode. → Turn to auto focus mode. (p. 58)• Shooting conditions are not suitable for autofocus. → Adjust focus manually. (p. 58)
The fader function does not work.	<ul style="list-style-type: none">• The digital effect function is working. → Cancel it. (p. 40)
A vertical band appears when you shoot a subject such as lights or a candle flame against a dark background.	<ul style="list-style-type: none">• The contrast between the subject and background is too high. This is not a malfunction.
Vertical streaks appear when you shoot a very bright subject.	<ul style="list-style-type: none">• This is called the smear phenomenon. This is not a malfunction.

Troubleshooting

Symptom	Cause and/or Corrective Actions
Some tiny white spots appear on the LCD screen or in the viewfinder.	<ul style="list-style-type: none">• When the shutter speed is too low or the low lux mode is selected.
Unknown pictures or messages are displayed on the LCD screen or in the viewfinder.	<ul style="list-style-type: none">• If 10 minutes elapse after you set the POWER switch to CAMERA or DEMO MODE is set to ON in the menu settings without a cassette inserted, your camcorder automatically starts the demonstration.<ul style="list-style-type: none">→ Insert a cassette. The demonstration stops.• You can also cancel DEMO MODE. (p. 112)
The click of the shutter does not sound.	<ul style="list-style-type: none">• BEEP is set to OFF in the menu settings.<ul style="list-style-type: none">→ Set it to MELODY or NORMAL. (p. 107)
The image is not bright even if you use the video flash light.	<ul style="list-style-type: none">• The ND FILTER selector is set to 1 or 2.<ul style="list-style-type: none">→ Set it to OFF. (p. 46)• The manual adjustment is not suitable for the situations. (The ⚡ indicator flashes.)<ul style="list-style-type: none">→ Set the AUTO LOCK selector to AUTO LOCK, or cancel the manual adjustment. (p. 43)

In the playback mode

Symptom	Cause and/or Corrective Actions
The tape does not move when a video control button is pressed.	<ul style="list-style-type: none">• The POWER switch is not set to VCR.<ul style="list-style-type: none">→ Set it to VCR. (p. 26)
The playback button does not function.	<ul style="list-style-type: none">• The tape has run out.<ul style="list-style-type: none">→ Rewind the tape. (p. 29)
There are horizontal lines on the picture or the playback picture is not clear or does not appear.	<ul style="list-style-type: none">• The video head may be dirty.<ul style="list-style-type: none">→ Clean the heads using the Sony DVM12CL cleaning cassette (not supplied). (p. 157)
No sound or only a low sound is heard when playing back a tape.	<ul style="list-style-type: none">• The volume is turned to minimum.<ul style="list-style-type: none">→ Turn up the volume. (p. 26)• AUDIO MIX is set to the ST2 side in the menu settings.<ul style="list-style-type: none">→ Adjust AUDIO MIX. (p. 107)
The title search function does not work.	<ul style="list-style-type: none">• The tape has no cassette memory.<ul style="list-style-type: none">→ Use a tape with cassette memory. (p. 66, 143)• CM SEARCH is set to OFF in the menu settings.<ul style="list-style-type: none">→ Set it to ON. (p. 107)• There is no title in the tape.<ul style="list-style-type: none">→ Superimpose the titles. (p. 97)• The tape has a blank portion in the recorded portion. (p. 66)

(continued on the following page)





Troubleshooting

Symptom	Cause and/or Corrective Actions
Displaying the recorded date, date search function does not work.	<ul style="list-style-type: none"> • The tape has no cassette memory. <ul style="list-style-type: none"> → Use a tape with cassette memory. (p. 67, 143) • CM SEARCH is set to OFF in the menu settings. <ul style="list-style-type: none"> → Set it to ON. (p. 107) • The tape has a blank portion in the recorded portion. (p. 68)
The new sound now being added, or that has been added to the recorded tape is not heard.	<ul style="list-style-type: none"> • AUDIO MIX is set to ST1 side in the menu settings. <ul style="list-style-type: none"> → Set it to the side you want to monitor. (p. 107)
The title is not displayed.	<ul style="list-style-type: none"> • TITLE DSPL is set to OFF in the menu settings. <ul style="list-style-type: none"> → Set it to ON. (p. 107)
The sound is muted or images do not appear when monitoring images through TV/VCR.	<ul style="list-style-type: none"> → Pull out the A/V connecting cable from the AUDIO L/R and VIDEO jacks, then connect it again.

In the recording and playback modes

Symptom	Cause and/or Corrective Actions
The power does not turn on.	<ul style="list-style-type: none"> • The battery pack is not installed, or is dead or nearly dead. <ul style="list-style-type: none"> → Install a charged battery pack. (p. 9, 10) • The AC power adaptor is not connected to a wall outlet. <ul style="list-style-type: none"> → Connect the AC power adaptor to a wall outlet. (p. 13)
The end search function does not work.	<ul style="list-style-type: none"> • The tape was ejected after recording when using a tape without cassette memory. (p. 25, 29) • You have not recorded on the new cassette yet. (p. 25, 29)
The end search function does not work correctly.	<ul style="list-style-type: none"> • The tape has a blank portion in the beginning or middle. (p. 25)
The picture does not appear in the viewfinder.	<ul style="list-style-type: none"> • The LCD panel is open. <ul style="list-style-type: none"> → Close the LCD panel. (p. 17)
The battery pack is quickly discharged.	<ul style="list-style-type: none"> • The operating temperature is too low. • The battery pack is not fully charged. <ul style="list-style-type: none"> → Charge the battery pack fully. (p. 10) • The battery pack is completely dead, and cannot be recharged. <ul style="list-style-type: none"> → Replace with a new battery pack. (p. 9)
The battery remaining indicator does not indicate the correct time.	<ul style="list-style-type: none"> • You have used the battery pack in an extremely hot or cold environment for a long time. • The battery pack is completely dead, and cannot be recharged. <ul style="list-style-type: none"> → Replace with a new battery pack. (p. 9) • The battery is dead. <ul style="list-style-type: none"> → Use a full-charged battery pack. (p. 9, 10)

Troubleshooting

Symptom	Cause and/or Corrective Actions
The cassette cannot be removed from the holder.	<ul style="list-style-type: none"> • The power source is disconnected. → Connect it firmly. (p. 9, 13) • The battery is dead. → Use a charged battery pack. (p. 9, 10)
The  and  indicators flash and no functions except for cassette ejection work.	<ul style="list-style-type: none"> • Moisture condensation has occurred. → Remove the cassette and leave your camcorder for at least one hour to acclimatize. (p. 156)
 indicator does not appear when using a tape with cassette memory.	<ul style="list-style-type: none"> • The gold-plated connector of the tape is dirty or dusty. → Clean the gold-plated connector. (p. 144)
Remaining tape indicator is not displayed.	<ul style="list-style-type: none"> • The  REMAIN is set to AUTO in the menu settings. → Set it to ON to always display the remaining tape indicator. (p. 107)

When operating using the "Memory Stick"

Symptom	Cause and/or Corrective Actions
Operations do not function.	<ul style="list-style-type: none"> • The POWER switch is set to CAMERA or OFF (CHG). → Set it to MEMORY or VCR. • The "Memory Stick" is not inserted. → Insert a "Memory Stick." (p. 117)
Recording does not function.	<ul style="list-style-type: none"> • The "Memory Stick" has already been recorded to its full capacity. → Erase unnecessary images and record again. (p. 120, 139) • The "Memory Stick" formatted incorrectly is inserted. → Format the "Memory Stick" or use another "Memory Stick." (p. 110) • The write-protect tab on the "Memory Stick" is set to LOCK. → Set the tab to write. (p. 115)
The image cannot be deleted.	<ul style="list-style-type: none"> • The image is protected. → Cancel image protection. (p. 138) • The write-protect tab on the "Memory Stick" is set to LOCK. → Set the tab to write. (p. 115)
You cannot format the "Memory Stick."	<ul style="list-style-type: none"> • The write-protect tab on the "Memory Stick" is set to LOCK. → Set the tab to write. (p. 115)
Deleting all the images cannot be carried out.	<ul style="list-style-type: none"> • The write-protect tab on the "Memory Stick" is set to LOCK. → Set the tab to write. (p. 115)
You cannot protect the image.	<ul style="list-style-type: none"> • The write-protect tab on the "Memory Stick" is set to LOCK. → Set the tab to write. (p. 115) • The image to be protected is not being played back. → Press MEMORY PLAY to play back the image. (p. 132)
You cannot write a print mark on the still image.	<ul style="list-style-type: none"> • The write-protect tab on the "Memory Stick" is set to LOCK. → Set the tab to write. (p. 115) • The image that you will write a print mark is not being played back. → Press MEMORY PLAY to play back the image. (p. 132)

(continued on the following page)

Troubleshooting

Symptom	Cause and/or Corrective Actions
The photo save function does not work.	<ul style="list-style-type: none">• The write-protect tab on the “Memory Stick” is set to LOCK. → Set the tab to write. (p. 115)• The battery pack is dead. → Install a charged battery pack or use the AC power adaptor instead of the battery pack. (p. 9, 13)

Others

Symptom	Cause and/or Corrective Actions
The title is not recorded.	<ul style="list-style-type: none">• The tape has no cassette memory. → Use a tape with cassette memory. (p. 97, 143)• The cassette memory is full. → Erase unnecessary title. (p. 100)• The tape is set to prevent accidental erasure. → Slide the write-protect tab so that red portion is not visible. (p. 14)• Nothing is recorded in that position on the tape. → Superimpose the title to the recorded position. (p. 97)
The cassette label is not recorded.	<ul style="list-style-type: none">• The tape has no cassette memory. → Use a tape with cassette memory. (p. 103, 143)• The cassette memory is full. → Erase some data. (p. 105)• The tape is set to prevent accidental erasure. → Slide the write-protect tab so that red portion is not visible. (p. 14)
While editing using the i.LINK cable (DV connecting cable), recording picture cannot be monitored.	<ul style="list-style-type: none">→ Disconnect the i.LINK cable (DV connecting cable), and connect it again. (p. 74)
Digital program editing does not function.	<ul style="list-style-type: none">• The input selector on the VCR is not set correctly. → Check the connection and set up the selector position. (p. 73)• The camcorder is not connected to Sony DV equipment. → Set CONTROL to IR in the menu settings and set the recording VCR to be controlled by infrared rays.• Setting program on a blank portion of the tape is attempted. → Set the program again on a recorded portion. (p. 84)• Your camcorder and the VCR are not synchronized. → Synchronize them. (p. 81)

Troubleshooting

Symptom	Cause and/or Corrective Actions
The Remote Commander supplied with your camcorder does not work.	<ul style="list-style-type: none">• COMMANDER is set to OFF in the menu settings. → Set it to ON. (p. 107)• Something is blocking the infrared rays. → Remove the obstacle.• The batteries are inserted in the battery holder with the + - polarities incorrectly. → Insert the batteries with the correct polarity. (p. 168)• The batteries are dead. → Insert new ones. (p. 168)
The picture from a TV or VCR does not appear even when your camcorder is connected to outputs on the TV or VCR.	<ul style="list-style-type: none">• DISPLAY is set to V-OUT/LCD in the menu settings. → Set it to LCD. (p. 107)
The melody or beep sounds for five seconds.	<ul style="list-style-type: none">• Moisture condensation has occurred. → Remove the cassette and leave your camcorder for at least one hour to acclimatize. (p. 156)• Some troubles have occurred in your camcorder. → Remove the cassette and insert it again, then operate your camcorder.
When charging the battery pack, no indicator appears or the indicator flashes on the display window.	<ul style="list-style-type: none">• The AC power adaptor is disconnected. → Connect it properly.• The battery pack malfunctions. → Contact your Sony dealer or local authorized Sony service facility.
You cannot charge the battery pack.	<ul style="list-style-type: none">• The POWER switch is not set to OFF (CHG). → Set it to OFF (CHG).
The camcorder is immediately turned off even if the amount of the battery remaining time is enough to operate.	<ul style="list-style-type: none">→ Charge the battery pack fully again. The correct remaining time is displayed.
No function works though the power is on.	<ul style="list-style-type: none">→ Disconnect the power cord of the AC power adaptor or remove the battery, then reconnect it after about one minute. Turn the power on. If the functions still do not work, press the RESET button located at the lower-right of the ZEBRA selector using a sharp-pointed object. (If you press the RESET button, all the settings including the date and time return to the default.) (p. 13, 163)

Self-diagnosis display

Your camcorder has a self-diagnosis display function.

This function displays the current condition of your camcorder as a 5-digit code (a combination of a letter and figures) on the LCD screen, display window, or in the viewfinder. If a 5-digit code is displayed, check the following code chart. The last two digits (indicated by □□) will differ depending on the state of your camcorder.

On the LCD screen or in the viewfinder, on the display window

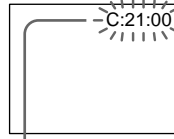

Self-diagnosis display

- C:□□:□□

You can service your camcorder yourself.

- E:□□:□□

Contact your Sony dealer or nearest local authorized Sony service facility.

Five-digit display	Cause and/or Corrective Actions
C:04:□□	<ul style="list-style-type: none"> • You are using a battery pack that is not an "InfoLITHIUM" battery pack. <ul style="list-style-type: none"> → Use an "InfoLITHIUM" battery pack. (p. 10)
C:21:□□	<ul style="list-style-type: none"> • Moisture condensation has occurred. <ul style="list-style-type: none"> → Remove the cassette and leave your camcorder for at least one hour to acclimatize. (p. 156)
C:22:□□	<ul style="list-style-type: none"> • The video heads are dirty. <ul style="list-style-type: none"> → Clean the heads using the Sony DVM12CL cleaning cassette (not supplied). (p. 157)
C:31:□□	<ul style="list-style-type: none"> • A malfunction other than the above. <ul style="list-style-type: none"> → Remove the cassette and insert it again, then operate your camcorder.
C:32:□□	<ul style="list-style-type: none"> • A malfunction other than the above. <ul style="list-style-type: none"> → Disconnect the power cord of the AC power adaptor or remove the battery pack. After reconnecting the power source, operate your camcorder.
E:61:□□	<ul style="list-style-type: none"> • A malfunction that you cannot service has occurred.
E:62:□□	<ul style="list-style-type: none"> • Contact your Sony dealer and inform them of the 5-digit code. (example: E:61:10)

If you are unable to rectify the problem even if you try corrective actions a few times, contact your Sony dealer or nearest local authorized Sony service facility.

Warning indicators and messages

If indicators and messages appear on the LCD screen or in the viewfinder, check the following: See the page in parentheses “()” for more information.

Warning indicators

 The battery is dead or nearly dead

Slow flashing:

- The battery is nearly dead.

Depending on conditions, the  indicator may flash, even if there are five to 10 minutes remaining. If this flashes, we recommend that you charge the battery or install the charged battery.

Fast flashing:

- The battery is dead (p. 10).
- The battery is completely dead.

 Warning indicator as to tape

Slow flashing:

- The tape is near the end.
- No tape is inserted (p. 14).*
- The write-protect tab on the cassette is out (red) (p. 14).*

Fast flashing:

- The tape has run out (p. 29).*

 You need to eject the cassette

Slow flashing:

- The write-protect tab on the cassette is out (red) (p. 14).*

Fast flashing:

- Moisture condensation has occurred (p. 156).*
- The tape has run out (p. 29).*
- The self-diagnosis display function is activated (p. 152).*

 Moisture condensation has occurred*

Fast flashing:

- Eject the cassette, turn off your camcorder, and leave it for about one hour with the cassette compartment open (p. 156).

 Warning indicator as to cassette memory

Slow flashing:

- No tape with cassette memory is inserted (p. 143).*

Self-diagnosis display (p. 152)

 The still image is protected

Slow flashing:

- The still image is protected (p. 138).*

 Warning indicator as to “Memory Stick”*

Slow flashing:

- No “Memory Stick” is inserted (p. 117).

Fast flashing:

- Unreadable “Memory Stick” is inserted.

Warning indicators and messages

100-0001 “(Warning indicators) Memory Stick” file error*

Slow flashing:















- File is broken.
- File has no compatibility.

 “Memory Stick” format error*

Fast flashing:

- There are too many directories or more.
- Data is broken.
- “Memory Stick” is not formatted correctly (p. 110).

Warning messages

- **CLOCK SET** Reset the date and time (p. 114).
- **FOR “InfoLITHIUM” BATTERY ONLY** Use an “InfoLITHIUM” battery pack (p. 10).
- **MEMORY FULL** The “Memory Stick” is full in photo save function (p. 131).
-  **CLEANING CASSETTE** The video heads are dirty (p. 157).**
-  **FULL** The tape cassette memory is full (p. 99).*
-  **16BIT** AUDIO MODE is set to 16BIT.* You cannot dub new sound (p. 111).
-  **REC MODE** REC MODE is set to LP.* You cannot dub new sound (p. 111).
-  **TAPE** There is no recorded portion on the tape.* You cannot dub new sound (p. 96).
-  **“i.LINK” CABLE** i.LINK cable is connected (p. 96).* You cannot dub new sound.
-  **FULL** The “Memory Stick” is full (p. 122).*
-  **LOCK** The write-protect tab on the “Memory Stick” is set to LOCK (p. 115).*
-  **NO FILE** No still image is recorded on the “Memory Stick” (p. 132).*
-  **NO MEMORY STICK** No “Memory Stick” is inserted (p. 117).*
-  **MEMORY STICK ERROR** The “Memory Stick” data is corrupted (p. 117).*
-  **FORMAT ERROR** (p. 110)*
-  **DIRECTORY ERROR** (p. 133)*
- **COPY INHIBIT** The tape contains copyright control signals for copyright protection of software (p. 143).*
-  **TAPE END** The tape has reached the end of the tape (p. 29).*
-  **NO TAPE** Insert a cassette tape (p. 14).*

* You hear the melody or beep sound.

**  and the message appear alternately.

Using your camcorder abroad

Using your camcorder abroad

You can use your camcorder in any country or area with the AC power adaptor supplied with your camcorder within 100 V to 240 V AC, 50/60 Hz.

When charging the battery pack, use a commercially available AC plug adaptor [a], if necessary, depending on the design of the wall outlet [b].

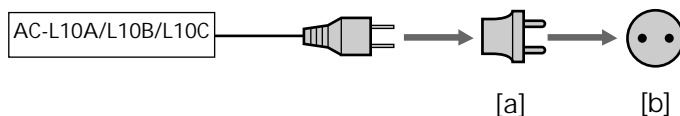

Your camcorder is an NTSC system based camcorder. If you want to view the playback picture on a TV, it must be an NTSC system based TV with the AUDIO/VIDEO input jack.

The following shows TV color systems used overseas.

NTSC system

Bahama Islands, Bolivia, Canada, Central America, Chile, Colombia, Ecuador, Jamaica, Japan, Korea, Mexico, Peru, Surinam, Taiwan, the Philippines, the U.S.A., Venezuela, etc.

PAL system

Australia, Austria, Belgium, China, Czech Republic, Denmark, Finland, Germany, Great Britain, Holland, Hong Kong, Italy, Kuwait, Malaysia, New Zealand, Norway, Portugal, Singapore, Slovak Republic, Spain, Sweden, Switzerland, Thailand, etc.

PAL-M system

Brazil

PAL-N system

Argentina, Paraguay, Uruguay

SECAM system



Bulgaria, France, Guyana, Hungary, Iran, Iraq, Monaco, Poland, Russia, Ukraine, etc.

Simple setting of clock by time difference

You can easily set the clock to the local time by setting a time difference. Select WORLD TIME in the menu settings. See page 107 for more information.

Maintenance information and precautions

Moisture condensation

If your camcorder is brought directly from a cold place to a warm place, moisture may condense inside your camcorder, on the surface of the tape, or on the lens. In this condition, the tape may stick to the head drum and be damaged or your camcorder may not operate correctly. If there is moisture inside your camcorder, the beep sounds and the  indicator flashes. When the  indicator flashes at the same time, the cassette is inserted in your camcorder. If moisture condenses on the lens, the indicator will not appear.

If moisture condensation occurred

None of the functions except cassette ejection will work. Eject the cassette, turn off your camcorder, and leave it for about one hour with the cassette compartment open. Your camcorder can be used again if the  indicator does not appear when the power is turned on again.

Note on moisture condensation

Moisture may condense when you bring your camcorder from a cold place into a warm place (or vice versa) or when you use your camcorder in a hot place as follows:

- You bring your camcorder from a ski slope into a place warmed up by a heating device.
- You bring your camcorder from an air-conditioned car or room into a hot place outside.
- You use your camcorder after a squall or a shower.
- You use your camcorder in a high temperature and humidity place.

How to prevent moisture condensation

When you bring your camcorder from a cold place into a warm place, put your camcorder in a plastic bag and tightly seal it. Remove the bag when the air temperature inside the plastic bag has reached the surrounding temperature (after about one hour).

Maintenance information and precautions

Removing Dust from Inside the Viewfinder

Before cleaning, remove the sticker below the viewfinder lens adjustment lever.

- (1) While holding down the hook ❶, slide the eyecup in the direction of the arrow and remove it out ❷.
- (2) Clean the surface with a commercially available blower.

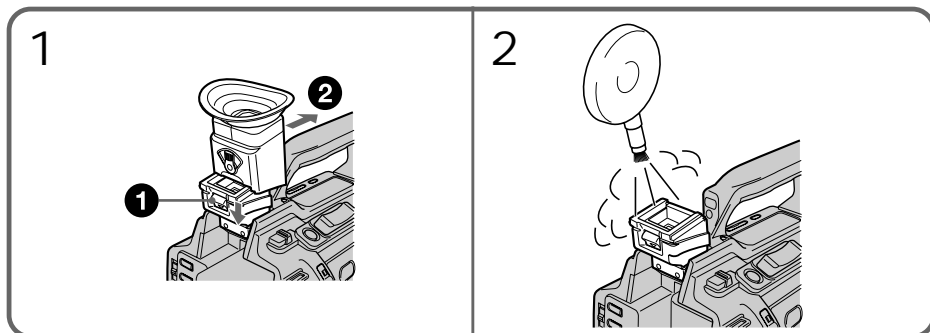

To reattach the eyecup

Do step 1 above sliding the eyecup in the reverse direction of the arrow.

Maintenance information

Cleaning the video head

To ensure normal recording and clear pictures, clean the video heads. The video head may be dirty when:

- mosaic-pattern noise appears on the playback picture.
- playback pictures do not move.
- playback pictures do not appear.
- the ⊗ indicator and "CLEANING CASSETTE" message appear one after another on the LCD screen or in the viewfinder.

If the above problem, [a] or [b] occurs, clean the video heads for 10 seconds with the Sony DVM12CL cleaning cassette (not supplied). Check the picture and if the above problem persists, repeat cleaning.

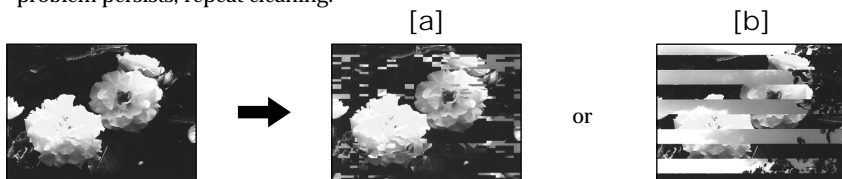

Cleaning the LCD screen

If fingerprints or dust make the LCD screen dirty, we recommend using a LCD Cleaning Cloth (not supplied) to clean the LCD screen.

Charging the vanadium-lithium battery in your camcorder

Your camcorder is supplied with a vanadium-lithium battery installed so as to retain the date and time, etc., regardless of the setting of the POWER switch. The vanadium-lithium battery is always charged as long as you are using your camcorder. The battery, however, will get discharged gradually if you do not use your camcorder. It will be completely discharged in about four months if you do not use your camcorder at all. Even if the vanadium-lithium battery is not charged, it will not affect the camcorder operation. To retain the date and time, etc., charge the battery if the battery is discharged.

Charging the vanadium-lithium battery:

- Connect your camcorder to house current using the AC power adaptor supplied with your camcorder, and leave your camcorder with the POWER switch turned off for more than 24 hours.
- Or install the fully charged battery pack in your camcorder, and leave your camcorder with the POWER switch turned off for more than 24 hours.

Precautions

Camcorder operation

- Operate your camcorder on 7.2 V (battery pack) or 8.4 V (AC power adaptor).
- For DC or AC operation, use the accessories recommended in this operating instructions.
- If any solid object or liquid get inside the casing, unplug your camcorder and have it checked by a Sony dealer before operating it any further.
- Avoid rough handling or mechanical shock. Be particularly careful of the lens.
- Keep the POWER switch set to OFF (CHG) when you are not using your camcorder.
- Do not wrap your camcorder with a towel, for example, and operate it. Doing so might cause heat to build up inside.
- Keep your camcorder away from strong magnetic fields or mechanical vibration. Noise may appear on the image.
- Do not touch the LCD screen with a sharp-pointed object.
- If your camcorder is used in a cold place, a residual image may appear on the LCD screen. This is not a malfunction.
- While using your camcorder, the back of the LCD screen may heat up. This is not a malfunction.

On handling tapes

- Do not insert anything into the small holes on the rear of the cassette. These holes are used to sense the type and thickness of the tape and if the recording tab is in or out.
- Do not open the tape protect cover or touch the tape.
- Avoid touching or damaging the terminals. To remove dust, clean the terminals with a soft cloth.

Camcorder care

- Remove the tape, and periodically turn on the power, operate the CAMERA and VCR sections and play back a tape for about three minutes when your camcorder is not to be used for a long time.
- Clean the lens with a soft brush to remove dust. If there are fingerprints on the lens, remove them with a soft cloth.
- Clean the camcorder body with a dry soft cloth, or a soft cloth lightly moistened with a mild detergent solution. Do not use any type of solvent which may damage the finish.

- Do not let sand get into your camcorder. When you use your camcorder on a sandy beach or in a dusty place, protect it from the sand or dust. Sand or dust may cause your camcorder to malfunction, and sometimes this malfunction cannot be repaired.

AC power adaptor

- Unplug the unit from the wall outlet when you are not using the unit for a long time. To disconnect the power cord, pull it out by the plug. Never pull the power cord itself.
- Do not operate the unit with a damaged cord or if the unit has been dropped or damaged.
- Do not bend the power cord forcibly, or place a heavy object on it. This will damage the cord and may cause fire or electrical shock.
- Prevent metallic objects from coming into contact with the metal parts of the connecting section. If this happens, a short may occur and the unit may be damaged.
- Always keep metal contacts clean.
- Do not disassemble the unit.
- Do not apply mechanical shock or drop the unit.
- While the unit is in use, particularly during charging, keep it away from AM receivers and video equipment. AM receivers and video equipment disturb AM reception and video operation.
- The unit becomes warm during use. This is not a malfunction.
- Do not place the unit in locations that are:
 - Extremely hot or cold
 - Dusty or dirty
 - Very humid
 - Vibrating

Battery pack

- Use only the specified charger or video equipment with the charging function.
- To prevent accident from a short circuit, do not allow metal objects to come into contact with the battery terminals.
- Keep the battery pack away from fire.
- Never expose the battery pack to temperatures above 60 °C (140 °F), such as in a car parked in the sun or under direct sunlight.
- Keep the battery pack dry.
- Do not expose the battery pack to any mechanical shock.
- Do not disassemble nor modify the battery pack.
- Attach the battery pack to video equipment securely.
- Charging while some capacity remains does not affect the original battery capacity.
- The battery pack is not resistant to water. Do not wet the battery pack.
- Unless you use the battery pack for a long period, store the battery pack after you charge it fully and use it completely once a year.
- Store the battery pack in a cool, dry place.

Notes on dry batteries

To avoid possible damage from battery leakage or corrosion, observe the following:

- Be sure to insert the batteries with the + – polarities matched to the + – marks.
- Dry batteries are not rechargeable.
- Do not use a combination of new and old batteries.
- Do not use different types of batteries.
- Current flows from batteries when you are not using them for a long time.
- Do not use leaking batteries.

Maintenance information and precautions

If batteries are leaking



- Wipe off the liquid in the battery compartment carefully before replacing the batteries.
- If you touch the liquid, wash it off with water.
- If the liquid get into your eyes, wash your eyes with a lot of water and then consult a doctor.

If any problem occurs, unplug your camcorder and contact your nearest Sony dealer.

Specifications



Video camera recorder

System

Video recording system
2 rotary heads
Helical scanning system
Audio recording system
Rotary heads, PCM system
Quantization: 12 bits (Fs 32 kHz, stereo 1, stereo 2), 16 bits (Fs48 kHz, stereo)
Video signal
NTSC color, standards
Usable cassette
Mini DV cassette with the ^{Mini}DV mark printed
Tape speed
SP: Approx. 18.81 mm/s
LP: Approx. 12.56 mm/s
Recording/playback time (using cassette DVM60)
SP: 1 h
LP: 1.5 h
Fast-forward/rewind time (using cassette DVM60)
Approx. 2 min and 30 s
Viewfinder
Electric viewfinder (color)
Image device
1/3 type CCD (3 Charge Coupled Device)
Approx. 380 000 pixels (Effective: Approx. 340 000 pixels)
Lens
Combined power zoom lens
Filter diameter 58 mm (2 3/8 in)
12× (Optical), 48× (Digital)
F1.6 - 2.4
Focal length
6 - 72 mm (1/4 - 2 7/8 in)
When converted to a 35 mm still camera
43.2 - 518.4 mm (1 3/4 - 20 1/2 in)
Color temperature
Auto,  Indoor (3 200 K),  Outdoor (5 800 K), 
Minimum illumination
2 lux (F1.6)

Input/Output connectors

S video input/output
Input/output auto switch
4-pin mini DIN
Luminance signal: 1 Vp-p, 75 ohms, unbalanced
Chrominance signal: 0.286 Vp-p, 75 ohms, unbalanced

Video input/output
Input/output auto switch
RCA pin-jack, 1 Vp-p, 75 ohms, unbalanced, sync negative
Audio input/output
Input/output auto switch
RCA pin-jack, 327 mV, (at output impedance more than 47 kilohms)
Output impedance with less than 2.2 kilohms
Input impedance more than 47 kilohms
Headphones jack
Stereo minijack (ø 3.5 mm)
 LANC control jack
Stereo mini-minijack (ø 2.5 mm)
MIC jack
Minijack, 0.388 mV low impedance with 2.5 to 3.0 V DC, output impedance 6.8 kilohms (ø 3.5 mm)
Stereo type
 DV input/output
4-pin connector
Speaker
Dynamic speaker (ø 20 mm)

LCD screen

Picture
2.5 type measured diagonally
49.9×37.3 mm (2 × 1 1/2 in)
Total dot number
200 640 (880 × 228)

General

Power requirements
7.2 V (battery pack)
8.4 V (AC power adaptor)
Average power consumption (when using the battery pack)
During camera recording using LCD
4.7 W
Viewfinder
4.0 W
Operating temperature
0 °C to 40 °C (32 °F to 104 °F)
Storage temperature
-20 °C to +60 °C (-4 °F to +140 °F)
Dimensions (approx.)
115 × 146 × 342 mm (4 5/8 × 5 3/4 × 13 1/2 in) (w/h/d)
Mass (approx.)
1.4 kg (3 lb 1 oz)
main unit only
1.6 kg (3 lb 8 oz)
including the battery pack,
NP-F330, cassette DVM60 and hood cap
Supplied accessories
See page 8.

AC power adaptor

Power requirements
100 - 240 V AC, 50/60 Hz
Power consumption
23 W
Output voltage
DC OUT: 8.4 V, 1.5 A in the operating mode
Operating temperature
0 °C to 40 °C (32 °F to 104 °F)
Storage temperature
-20 °C to +60 °C (-4 °F to +140 °F)
Dimensions (approx.)
125 × 39 × 62 mm
(5 × 1 9/16 × 2 1/2 in) (w/h/d) excluding projecting parts
Mass (approx.)
280 g (9.8 oz) excluding power cord
Cord length (approx.)
Power cord: 2 m (6.6 feet)
Connecting cord: 1.6 m (5.2 feet)

Battery pack

Output voltage
DC 7.2 V
Capacity
5.0 Wh
Dimensions (approx.)
38.4 × 20.6 × 70.8 mm (1 9/16 × 13/16 × 2 7/8 in) (w/h/d)
Mass (approx.)
70 g (2.5 oz)
Type
Lithium ion

"Memory Stick"

Memory
Flash memory
4 MB: MSA-4A
Operating voltage
2.7 V -3.6 V
Power consumption
Approx. 45 mA in the operating mode
Approx. 130 µA in the standby mode
Dimensions (approx.)
50 × 2.8 × 21.5 mm
(2 × 1/8 × 7/8 in) (w/h/d)
Mass (approx.)
4 g (0.14 oz)

Design and specifications are subject to change without notice.

Identifying the parts and controls

Camcorder

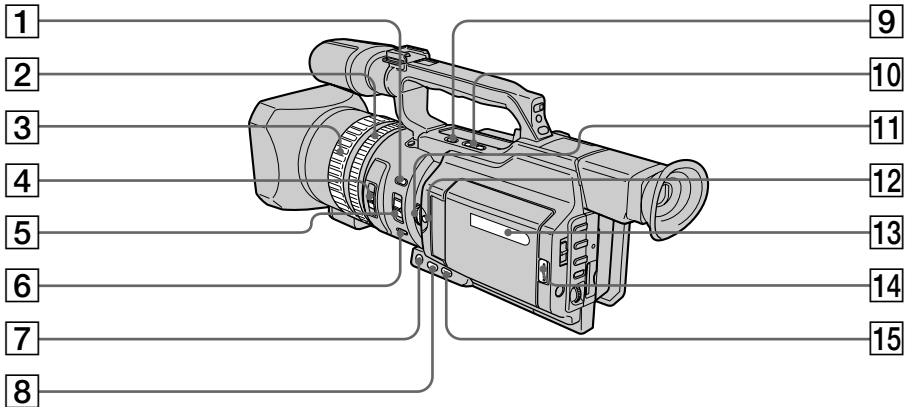

- | | |
|-------------------------------------|--------------------------------------|
| 1 INDEX MARK button (p. 62) | 8 BACK LIGHT button (p. 22) |
| 2 Zoom ring (p. 20) | 9 END SEARCH button (p. 25) |
| 3 Focus ring (p. 58) | 10 EDITSEARCH buttons (p. 25) |
| 4 ND FILTER selector (p. 46) | 11 EXPOSURE dial (p. 44) |
| 5 FOCUS selector (p. 58) | 12 EXPOSURE button (p. 44) |
| 6 PUSH AUTO button (p. 58) | 13 Display window (p. 168) |
| 7 FADER button (p. 38) | 14 OPEN button (p. 15, 26) |
| | 15 SPOT LIGHT button (p. 23) |



This mark indicates that this product is a genuine accessory for Sony video products.

When purchasing Sony video products, Sony recommends that you purchase accessories with this "GENUINE VIDEO ACCESSORIES" mark.

Mini **DV** Digital Video Cassette

CM Cassette Memory

These are trademarks of Sony corporation.



Notes on the intelligent accessory shoe

- The intelligent accessory shoe supplies power to optional accessories such as a video light or microphone.
- The intelligent accessory shoe is linked to the POWER switch, allowing you to turn the power supplied by the shoe on and off. Refer to the operating instructions of the accessory for further information.
- The intelligent accessory shoe has a safety device for fixing the installed accessory securely. To connect an accessory, press down and push it to the end, and then tighten the screw.
- To remove an accessory, loosen the screw, and then press down and pull out the accessory.

Identifying the parts and controls

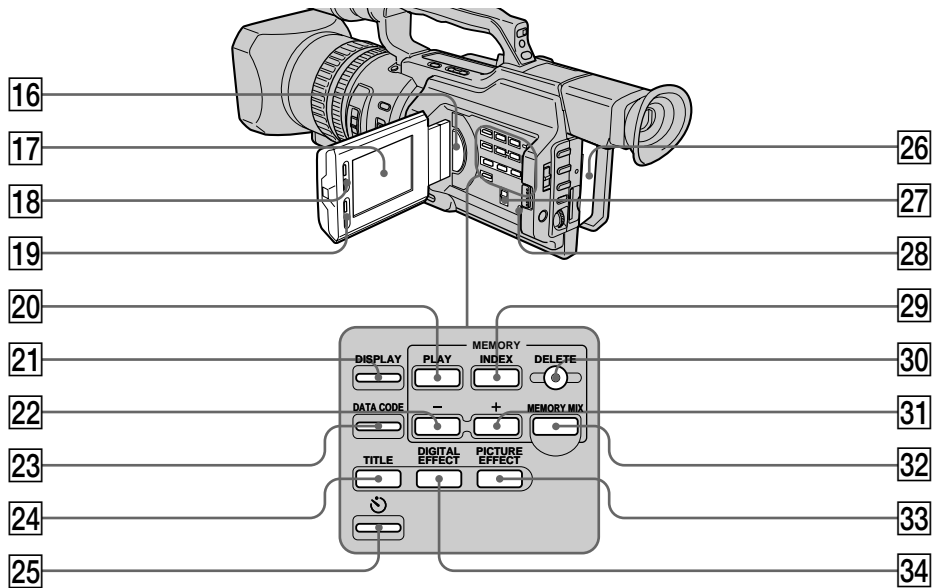

- | | | | |
|----|--|----|-------------------------------|
| 16 | Speaker | 26 | Battery pack (p. 9) |
| 17 | LCD screen (p. 17) | 27 | ZEBRA selector (p. 47) |
| 18 | LCD BRIGHT buttons (p. 18) | 28 | RESET button (p. 151) |
| 19 | VOLUME buttons (p. 26) | 29 | MEMORY INDEX button (p. 133) |
| 20 | MEMORY PLAY button (p. 132) | 30 | MEMORY DELETE button (p. 139) |
| 21 | DISPLAY button (p. 27) | 31 | MEMORY + button (p. 125, 132) |
| 22 | MEMORY - button (p. 125, 132) | 32 | MEMORY MIX button (p. 125) |
| 23 | DATA CODE button (p. 27) | 33 | PICTURE EFFECT button (p. 39) |
| 24 | TITLE button (p. 97) | 34 | DIGITAL EFFECT button (p. 41) |
| 25 | ⌚ (self-timer) button (p. 24, 32, 123) | | |

Identifying the parts and controls

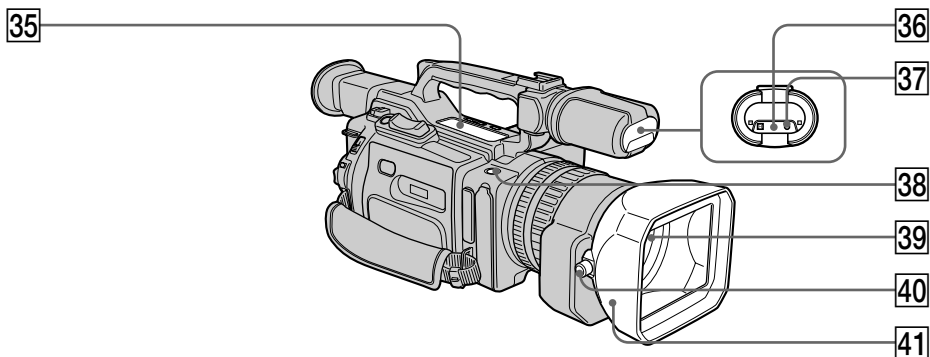

35 Video control buttons (p. 26, 29, 83)

||▶ SLOW (slow playback)

● AUDIO DUB (dubbing)

■ STOP (stop)

◀◀ REW (rewind)

▶▶ PLAY (playback)

▶▶ FF (Fast-forward)

|| PAUSE (pause)

● REC (recording)

The control buttons light up when you set the POWER switch to VCR.

37 Camera recording lamp (p. 15)

38 REC START/STOP (p. 18)

39 Lens

40 Lens hood fixing screw

41 Lens hood

You can attach a wide teleconversion lens (not supplied) by removing the lens hood.

36 Remote sensor/infrared ray emitter

Removing the lens hood

To remove the lens hood for attachment of the wide teleconversion lens, etc., loosen the lens hood fixing screw, and unscrew the lens hood counterclockwise.

When using additional filters

We recommend that you use Sony made filters having the genuine accessory mark.

Identifying the parts and controls

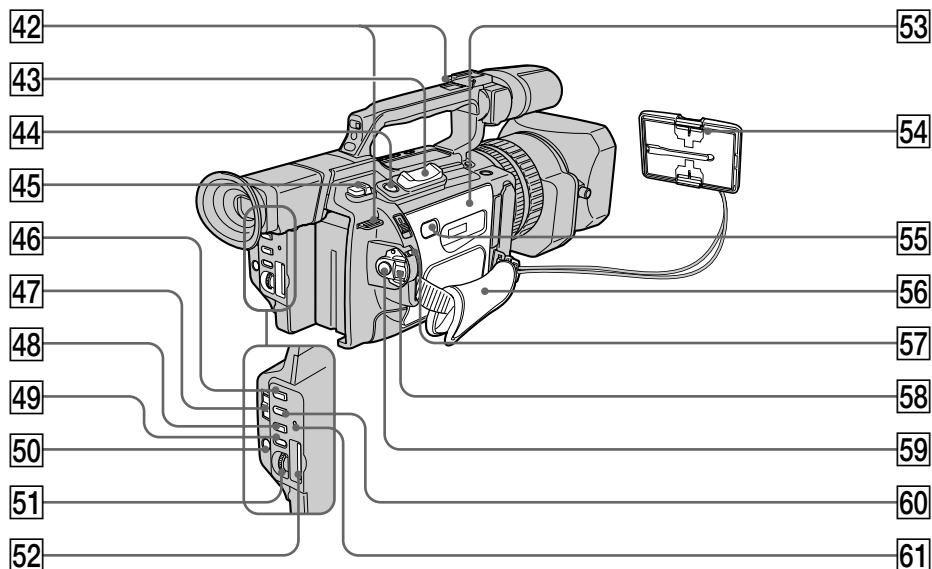

- | | |
|---|--|
| 42 Hooks for shoulder strap | 52 "Memory Stick" slot (p. 117) |
| 43 Power zoom lever (p. 20) | 53 Cassette lid (p. 14) |
| 44 PHOTO button (p. 31, 120) | 54 Hood cap (p. 15) |
| 45 BATT (battery) RELEASE lever (p. 9) | 55 PUSH button (p. 14) |
| 46 PROGRAM AE button (p. 56) | 56 Grip strap |
| 47 AUTO LOCK selector (p. 43) | 57 LOCK switch (p. 15) |
| 48 WHT BAL button (p. 49) | 58 POWER switch (p. 15) |
| 49 AUDIO LEVEL button (p. 51) | 59 START/STOP button (p. 15) |
| 50 MENU button (p. 107) | 60 SHUTTER SPEED button (p. 45) |
| 51 SEL/PUSH EXEC dial (p. 107) | 61 Access lamp (p. 117) |

Fastening the grip strap

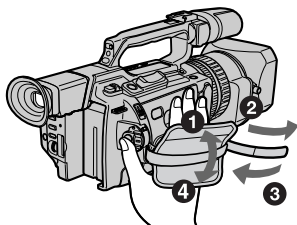

Fasten the grip strap firmly.





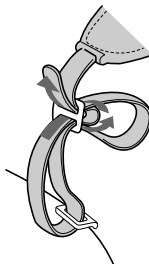

Attaching the shoulder strap

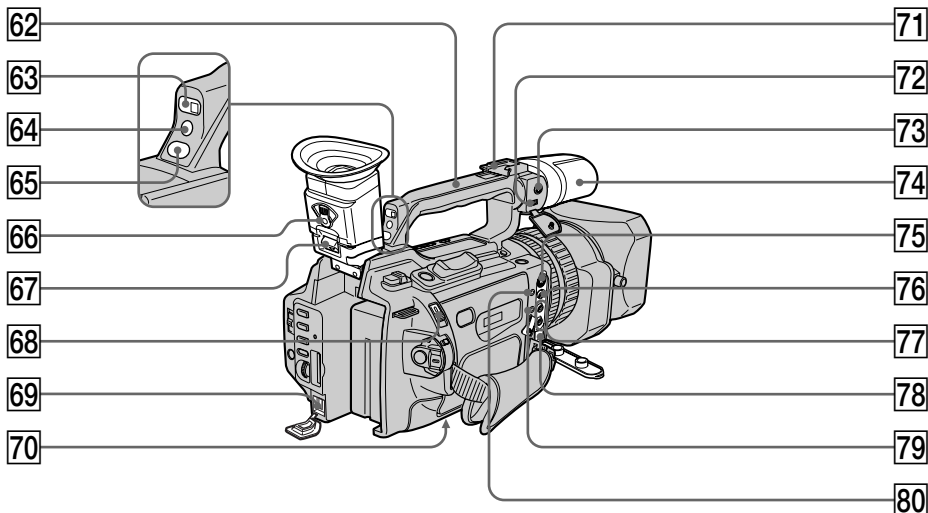
Attach the shoulder strap supplied with your camcorder to the hooks for the shoulder strap.



Identifying the parts and controls



- 62 Carrying handle
- 63 Remote sensor
- 64 Camera recording lamp (p. 15)
- 65 CUSTOM PRESET button (p. 53)
- 66 Viewfinder adjustment lever (p. 19)
- 67 Hook for removing the viewfinder (p. 157)
- 68 EJECT switch (p. 14)
- 69 DC IN jack (p. 10)
- 70 Tripod receptacle
Make sure that the length of the tripod screw is less than 6.5 mm (9/32 inch). Otherwise, you cannot attach the tripod securely and the screw may damage your camcorder.
- 71 Intelligent accessory shoe
- 72 MIC/LINE switch (p. 93)
- 73 MIC jack (PLUG IN POWER) (p. 93)
Connect an external microphone (not supplied). This jack also accepts a “plug-in-power” microphone.
When using a “plug-in-power” microphone, set the MIC/LINE switch to MIC, when using a non-“plug-in-power” microphone or audio equipment, set the MIC/LINE switch to LINE.
- 74 Microphone (p. 94)
- 75 S VIDEO ID-2 jack (p. 30, 33, 73, 87, 128)
- 76 VIDEO ID-2 jack (p. 30, 33, 73, 87, 128)
- 77 AUDIO L/R jack (p. 30, 73, 87, 94)
- 78  DV IN/OUT jack (p. 74, 89, 129)
This “i.LINK” mark is a trademark of Sony Corporation and indicates that this product is in agreement with IEEE 1394-1995 specifications and their revisions.
- The  DV IN/OUT jack is i.LINK compatible.
- 79  LANC jack
 LANC stands for Local Application Control Bus System. The  LANC control jack is used for controlling the tape transport of video equipment and peripherals connected to it. This jack has the same function as the jack indicated as CONTROL L or REMOTE.
- 80  (headphones) jack
When you use headphones, the speaker on your camcorder is silent.

Identifying the parts and controls

Remote Commander

The buttons that have the same name on the Remote Commander as on your camcorder function identically to the buttons on your camcorder.

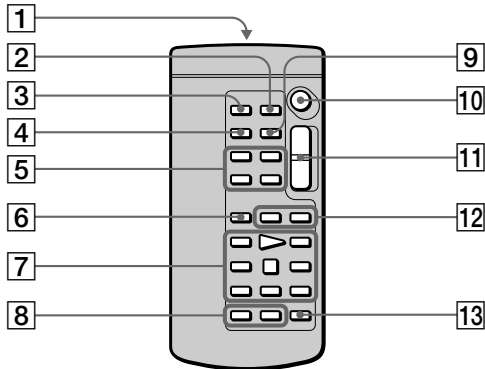

- | | |
|---|--|
| 1 Transmitter
Point toward the remote sensor to control your camcorder after turning on your camcorder. | 9 DATA CODE button (p. 27) |
| 2 ZERO SET MEMORY button (p. 63) | 10 START/STOP button (p. 15) |
| 3 PHOTO button (p. 31, 120) | 11 Power zoom button (p. 20) |
| 4 DISPLAY button (p. 27) | 12 ◀▶ buttons (p. 64, 66, 67, 69) |
| 5 Memory control buttons (p. 125, 132) | 13 AUDIO DUB button (p. 95) |
| 6 SEARCH MODE button
(p. 64, 66, 67, 69) | |
| 7 Video control buttons (p. 29) | |
| 8 REC button (p. 87)/MARK button
(p. 83) | |

Identifying the parts and controls

To prepare the Remote Commander

Insert two size AA (R6) batteries by matching the + and - polarities on the batteries to the + - marks inside the battery compartment.

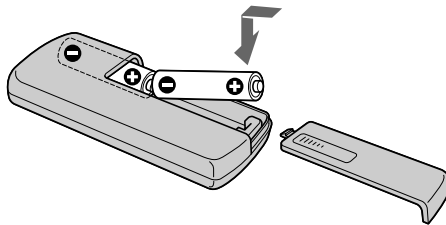

Notes on the Remote Commander

- Point the remote sensor away from strong light sources such as direct sunlight or overhead lighting. Otherwise, the Remote Commander may not function properly.
- Your camcorder works in the commander mode VTR 2. Commander modes 1, 2 and 3 are used to distinguish your camcorder from other Sony VCRs to avoid remote control misoperation. If you use another Sony VCR in the commander mode VTR 2, we recommend changing the commander mode or covering the sensor of the VCR with black paper.

Display window

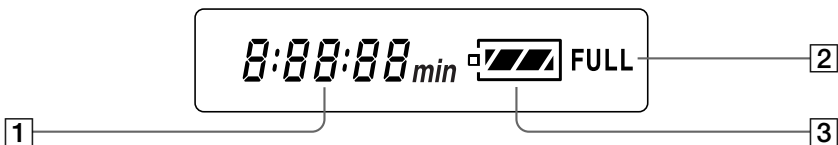

- 1 Remaining battery time indicator (p. 10)/Tape counter (p. 63)/Memory counter (p. 133)/Time code indicator (p. 21)/Self-diagnosis indicator (p. 152)
- 2 FULL charge indicator (p. 10)
- 3 Remaining battery indicator (p. 10)

Operation indicators

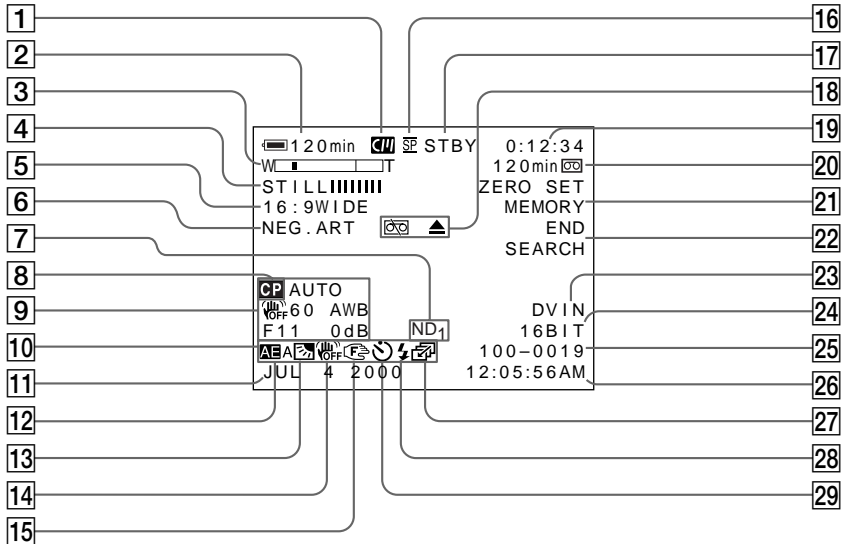

- 1 Cassette memory indicator (p. 143)
- 2 Remaining battery time indicator (p. 21)
- 3 Zoom indicator (p. 20)/Exposure indicator (p. 44)/Data file name indicator (p. 115)
- 4 Digital effect indicator (p. 40)/FADER indicator (p. 37)/MEMORY MIX indicator (p. 125)
- 5 16:9WIDE indicator (p. 36)/PROG. SCAN indicator (p. 34)
- 6 Picture effect indicator (p. 39)
- 7 ND filter indicator (p. 46)
- 8 Custom preset indicator (p. 53)
- 9 Data code indicator (p. 28)
- 10 LCD bright indicator (p. 18)/Volume indicator (p. 26)
- 11 Date indicator
- 12 PROGRAM AE indicator (p. 55)
- 13 Backlight indicator (p. 22)/Spot light indicator (p. 23)
- 14 SteadyShot OFF indicator (p. 108)
- 15 Manual focus/Infinity indicator (p. 58)
- 16 Recording mode indicator (p. 111)
- 17 Standby/Recording indicator (p. 15)/Video control mode indicator (p. 29)/
- 18 Image quality mode indicator (p. 118)
- 18 Warning indicators (p. 153)
- 19 Tape counter indicator (p. 63)/Time code indicator (p. 21)/Self-diagnosis indicator (p. 152)/Photo mode indicator (p. 31)/Image number indicator (p. 133)
- 20 Remaining tape indicator (p. 21)/Memory playback indicator (p. 133)
- 21 ZERO SET MEMORY indicator (p. 63)/FRAME REC indicator (p. 61)/Interval recording indicator (p. 59)
- 22 END SEARCH indicator (p. 25)
- 23 DV IN indicator (p. 90)/A/V→DV OUT indicator
- 24 Audio mode indicator (p. 111)
- 25 Data file name indicator
This indicator appears when the MEMORY MIX functions work.
- 26 Audio input level/Time indicator
- 27 Continuous mode indicator (p. 122)
- 28 Video flash ready indicator
This indicator appears when you use the video flash light (not supplied).
- 29 Self-timer indicator (p. 24)

Quick Function Guide

Functions to adjust exposure (in the recording mode)

- In insufficient light Low lux mode (p. 55)
- In dark environments such as sunset, fireworks, or general night views Sunset & moon mode (p. 55)
- Shooting backlit subjects BACK LIGHT (p. 22)
- In spotlight, such as at the theater or a formal event SPOT LIGHT (p. 23)

Functions to give images more impact (in the recording mode)

- Smooth transition between scenes FADER (p. 37)
- Taking a still picture PHOTO (p. 31, 120)
- Digital processing of images PICTURE EFFECT (p. 39)/
DIGITAL EFFECT (p. 40)
- Superimposing a title TITLE (p. 97)

Functions to give a natural appearance to your recordings (in the recording mode)

- Preventing deterioration of picture quality in digital zoom D ZOOM [MENU] (p. 107)
- Focusing manually Manual focus (p. 58)
- Recording fast-moving subjects Sports lesson mode (p. 55)

Functions to be used in editing (in the recording mode)

- Watching the picture on a wide-screen TV Wide mode (p. 36)
- Viewing images using a personal computer "Memory Stick" (p. 115)

Functions to be used after recording (in the playback mode)

- Digital processing of recorded images PICTURE EFFECT (p. 71)/
DIGITAL EFFECT (p. 72)
- Displaying the date/time or various settings when you recorded Data code (p. 28)
- Quickly locating a desired scene Zero set memory (p. 63)
- Searching for scenes having a title Title search (p. 66)
- Searching for scenes recorded in the photo mode Photo search (p. 69)
- Scanning scenes recorded in the photo mode Photo scan (p. 70)
- Playing back monaural sound or sub sound HiFi SOUND [MENU] (p. 107)

Index

A, B

A/V connecting cable 30, 73, 87
AC power adaptor 10
Adjusting shutter speed 45
Adjusting viewfinder 19
AE SHIFT 53
Audio dubbing 93
AUDIO LEVEL 51
AUDIO MIX 109
Audio mode 111
AUTO SHTR 108
BACK LIGHT 22
Battery pack 9
BEEP 113

C, D

Camera chromakey 124
Cassette memory 6, 143
Charging battery 10
Charging vanadium-lithium battery 158
Clock set 114
COLOR BAR 113
Connection
 (dubbing a tape) 73
 (viewing on TV) 30
Continuous 121
Custom preset 53
Cut recording 61
Data code 28
Date search 67
Date/time indicator 28
DEMO 112
DIGITAL EFFECT 40
Digital program editing 75
DISPLAY 27
DOT 37
Dual sound track tape 144
Dubbing a tape 73
DV connecting cable 74

E

EDITSEARCH 25
END SEARCH 25, 29
Exposure 44
External microphone (not supplied) 166

F, G, H

Fade in/out 37
FADER 37
FLASH MOTION 40
FOCUS 58
Format 110

Full charge 10
Grip strap 165
Guide frame 35
Headphones jack 166
Heads 157
HiFi SOUND 109

I, J, K, L

i.LINK 166
Image protection 138
Image quality mode 118
INDEX MARK 62
INDEX (Multiple)
 display 133
Index search 64
"InfoLITHIUM" battery 10
Intelligent accessory shoe 94
Interval recording 59
JPEG 115
Labeling a cassette 103
LANC 166
LCD screen 17
LUMINANCEKEY 40

M, N

Main sound 109
Manual adjustment 43
Manual focus 58
Memory chromakey 124
Memory luminancekey 124
Memory mix 124
Memory overlap 124
Memory photo recording .. 120
"Memory Stick" 115
Menu settings 107
MIC (PLUG IN POWER) 93
Mirror mode 17
Moisture condensation 156
MONOTONE 37
ND filter 46
Normal charge 10
NTSC system 155

O, P, Q

OLD MOVIE 40
Operation indicators 169
OVERLAP 37
Photo scan 70
Photo search 69
PICTURE EFFECT 39
Picture search 29
Playback pause 29
Power sources
 (battery pack) 9
 (car battery) 13
 (house current) 13

Power zoom 20
Print mark 142
PROGRAM AE 55
Progressive 34

R, S

Rec Review 25
Recording level 51
Recording time 11
Remaining battery time
 indicator 21
Remaining tape indicator ... 21
Remote Commander 167
Remote control jack (LANC)
 166
Remote sensor 164
RESET 151
S VIDEO jack 30, 73, 87
SEL/PUSH EXEC dial 107
Self-diagnosis display 152
Self-timer 24, 32, 123
Serial port adaptor 134
Skip scan 29
Slide show 137
Slow playback 29
Spotlight mode 23
STEADYSHOT 108
Stereo tape 144
STILL 40
Sub sound 109

T, U, V

Tape counter 63
Tape photo recording 31
Telephoto 20
Time code 21
Title 97
Title search 66
TRAIL 40
Transition 16
TV color system 155

W, X, Y, Z

Warning indicators 153
White balance 49
Wide mode 36
Wide-angle 20
WIPE 37
WORLD TIME 112
Write-protect tab 14
Zebra pattern 47
Zero set memory function ... 63
Zoom 20

Sony  line <http://www.world.sony.com/>

Printed on recycled paper

Printed using vegetable oil ink with less than
1% VOC (Volatile Organic Compound).
